

SELINE CHECKOUT ZONE

**SPEED AND
CONVENIENCE OF
SERVICE FOR YOUR
EFFICIENT STORE**

M^DERN EXPO

A modern grocery store checkout area. In the background, a sign reads "fresh and natural" in a light blue font. The checkout counter is white and has "EVO" printed on it. There are several vertical light fixtures above the counter. To the right, there is a large window with a view of trees and a building. The overall lighting is bright and modern.

fresh and natural

Modern shoppers are becoming more experience-oriented and want the payment process to run smoothly and quickly

This factor led to some major changes in the image of physical stores, especially their checkout zones



SELINE is a range of products for modern checkout zone. It was designed to meet the new customers' expectations based on speed, convenience, digitalization and personalization of the shopping experience

A photograph of a modern grocery store checkout area. In the foreground, a cashier is seated at a white, curved checkout counter labeled 'EVO'. The counter is equipped with a computer monitor and a scanner. In the background, there are several more checkout counters and aisles of shelves stocked with various products. Signs above the aisles indicate sections for 'SWEETS', 'SNACKS', 'GROCERY', and 'DRINKS'. The overall atmosphere is clean and organized.

Even today, checkout counters remain the core of the checkout zone

Meet EVO – stylish checkout counters that guarantee the highest comfort of the payment process

EVO



**EVO
MINI**



**EVO
EXPRESS**



**EVO checkout
counters** are designed to
meet the diverse needs of
various retail formats

The modularity of EVO counters allows customizing the layout and design to match every store's unique style and functional requirements

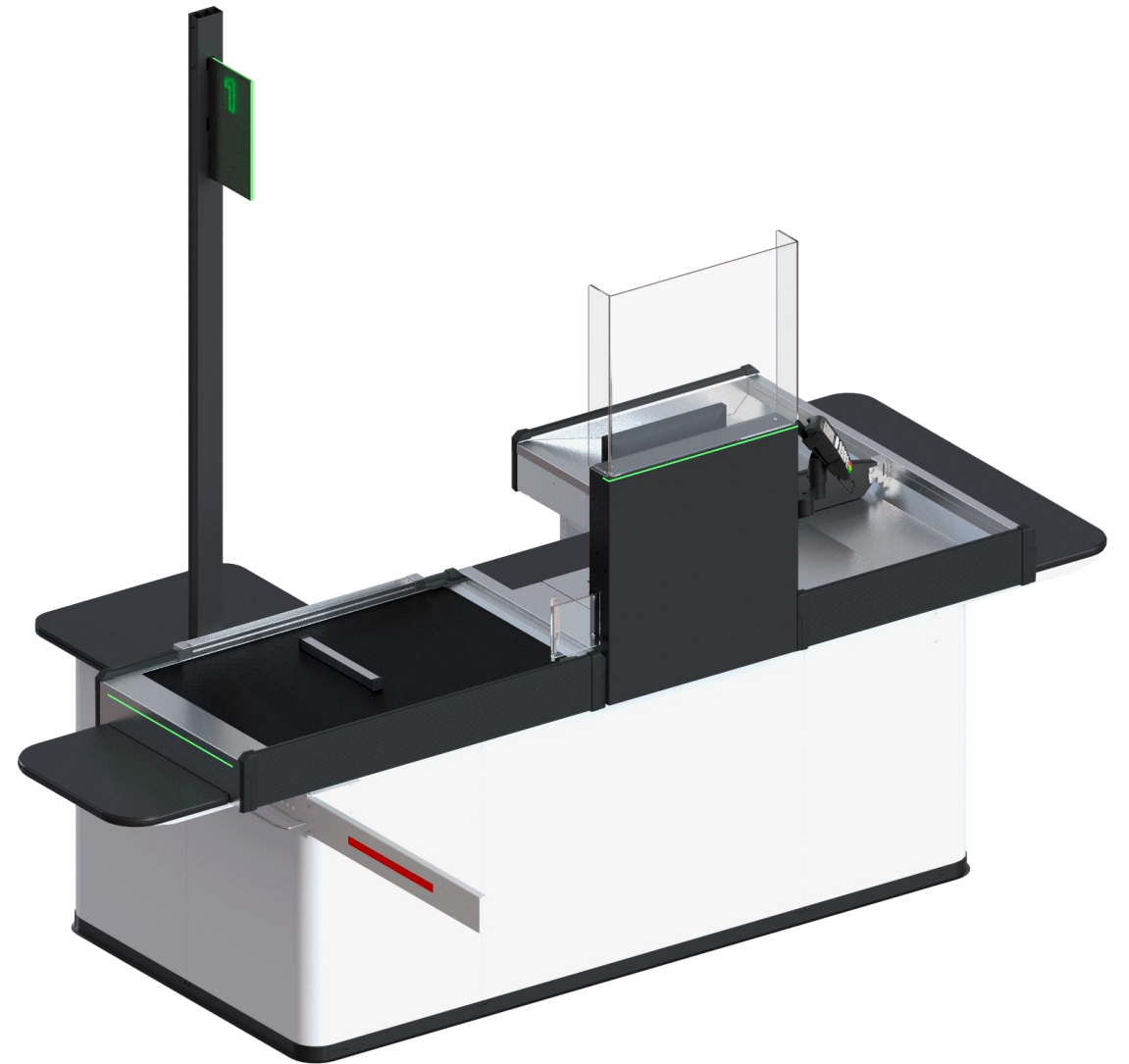

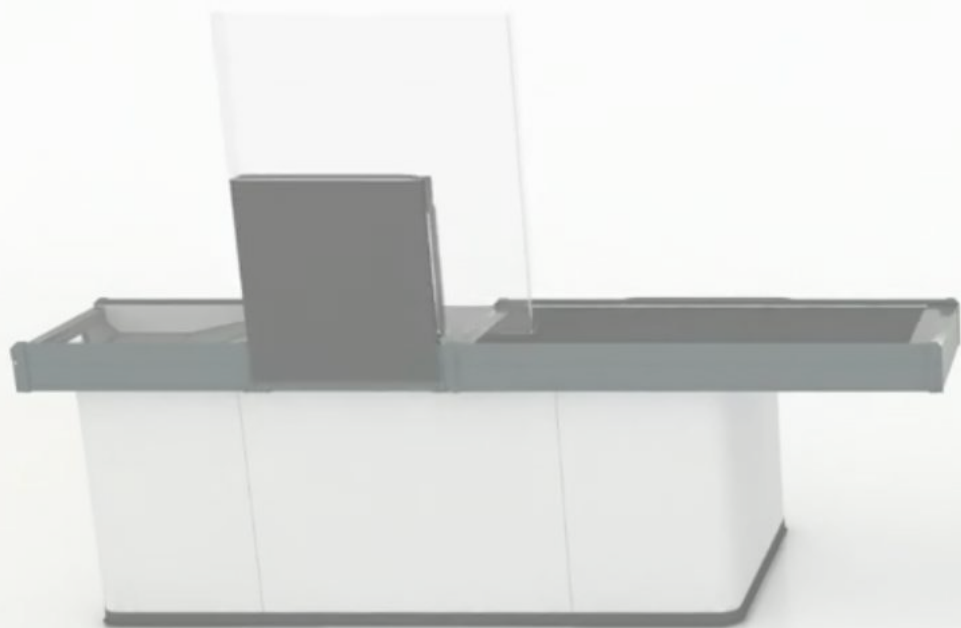

watch here

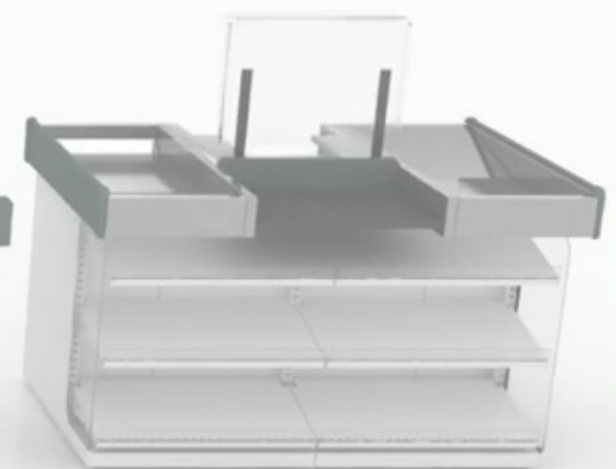

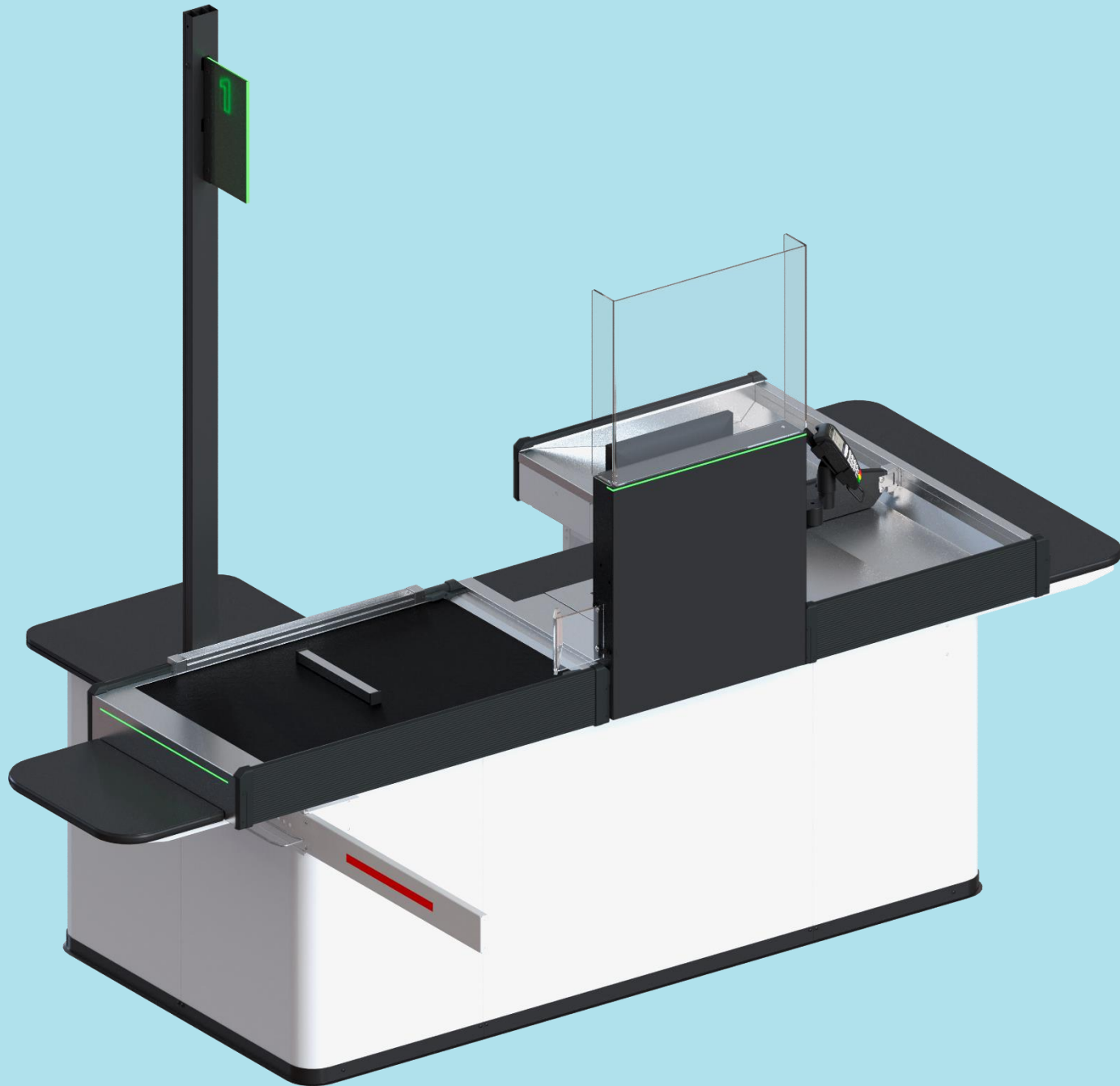

EVO SELINE: Type ONE

- Checkout counter with a wide basin and cashier's desk
- The format of stores from supermarkets to hypermarkets

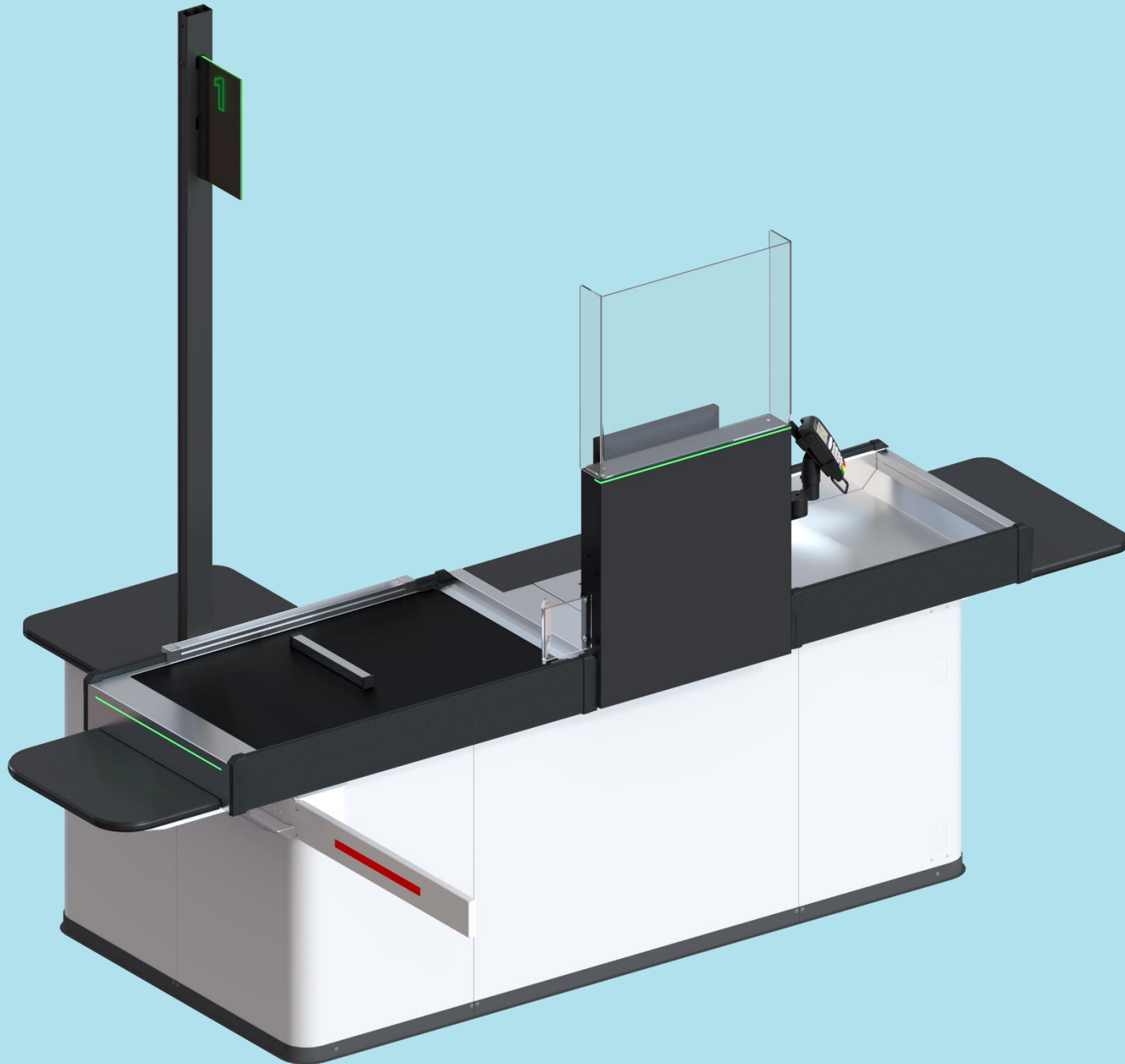

EVO SELINE: Type TWO

- Checkout counter with a narrow basin and cashier's desk
- The format of stores from convenience stores to supermarkets

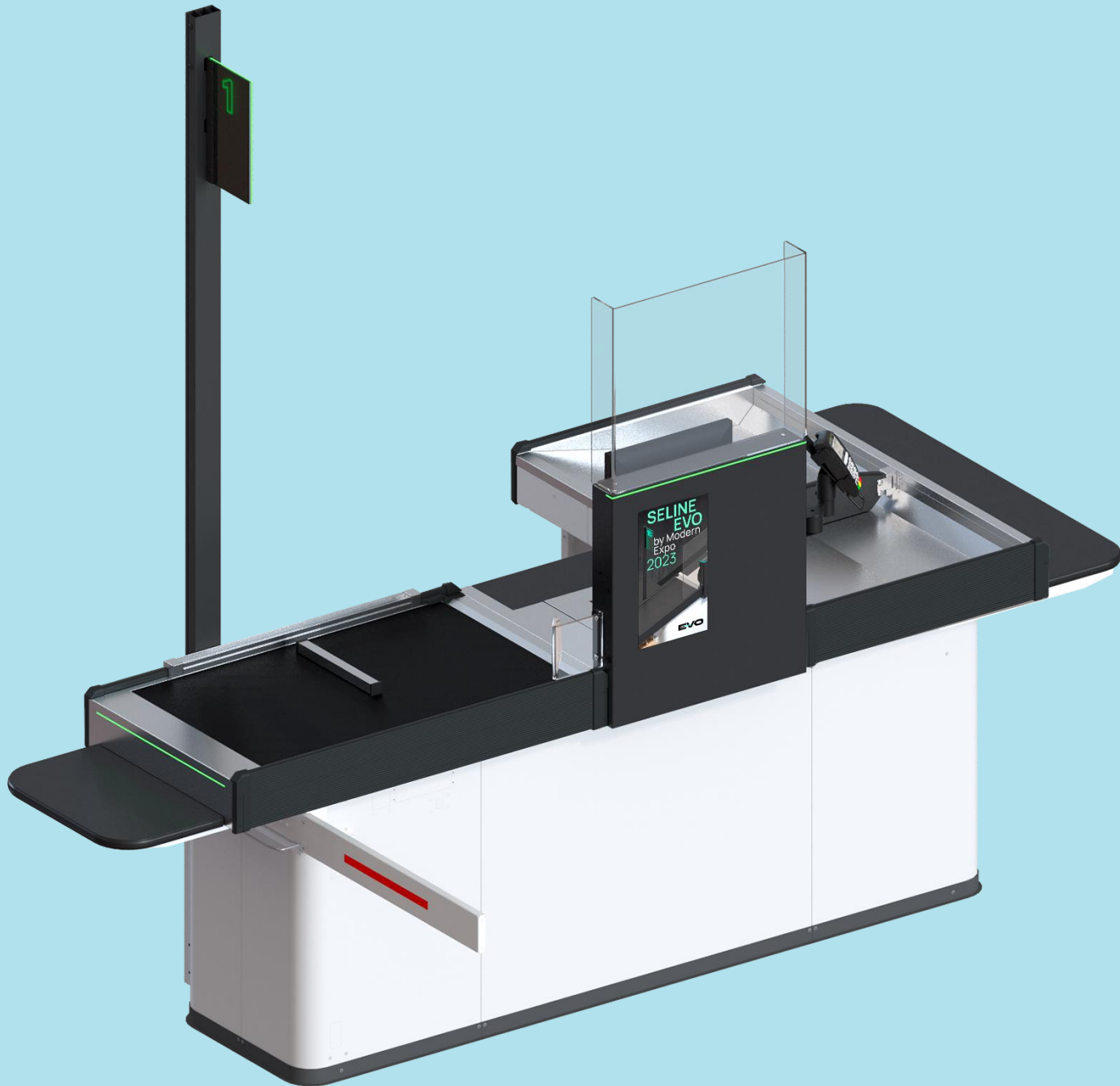

EVO SELINE: Type THREE

- Checkout counter with a wide basin
- The format of stores from supermarkets to hypermarkets and even Cash & Carry



EVO SELINE: Type FOUR

- Checkout counter with narrow basin
- The format of stores from convenience stores to supermarkets and even Cash & Carry

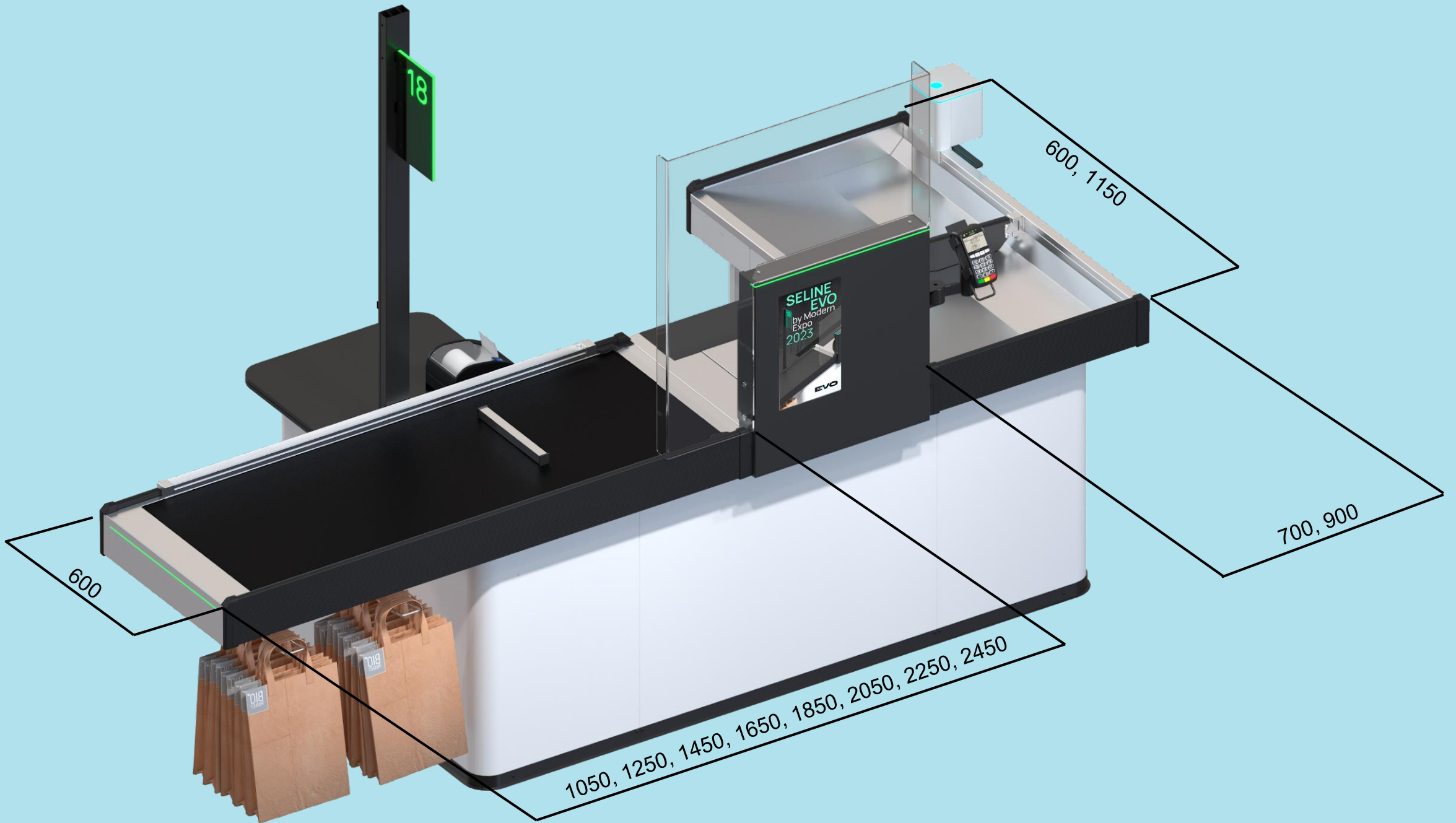

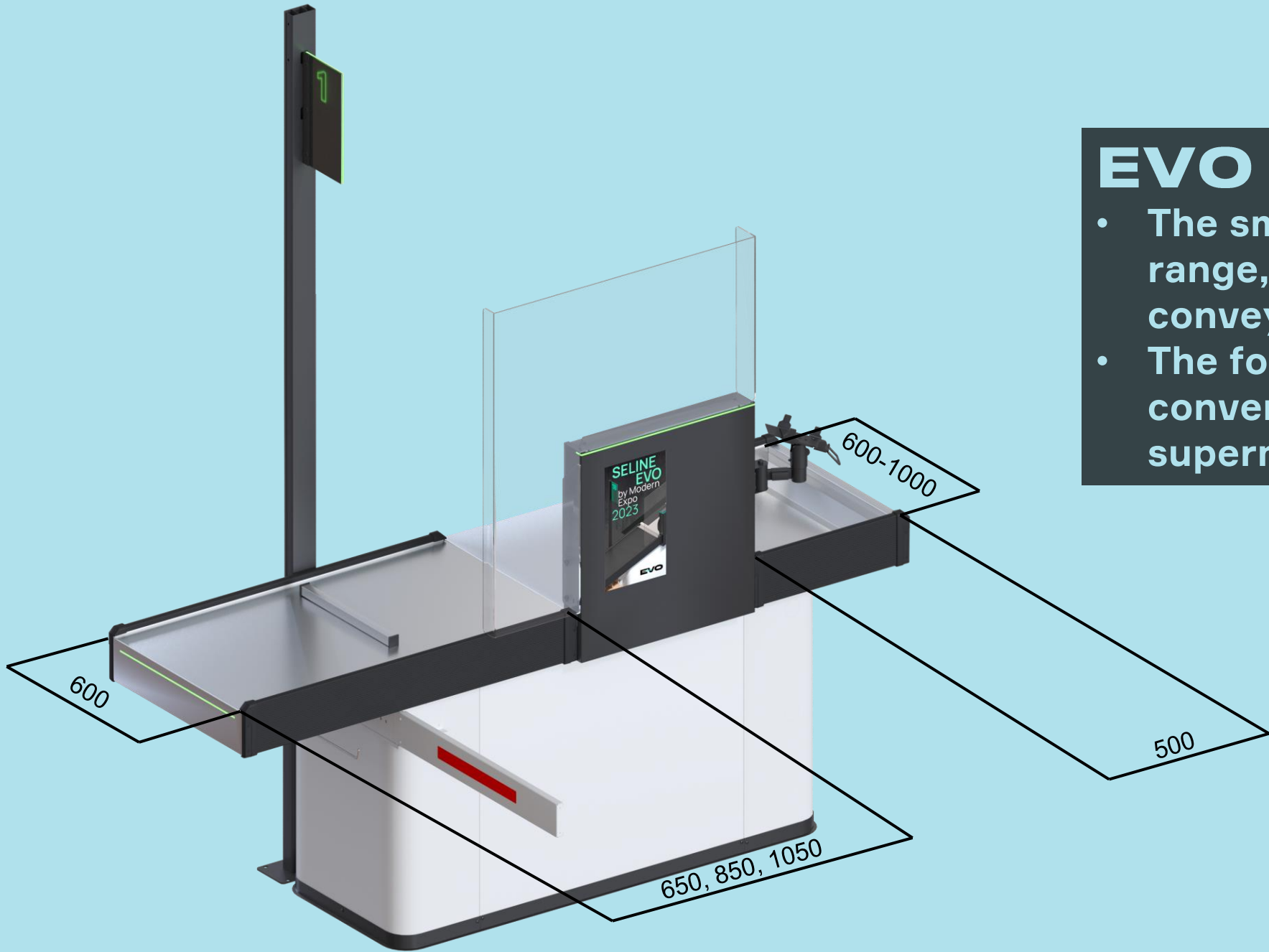

EVO MINI

- The smallest model from a range, with a static conveyor
- The format of stores from convenience stores to supermarkets and DIY



EVO EXPRESS

- Universal checkout module
- The format of stores from convenience stores and petrol stations to additional checkout zone in supermarkets and hypermarkets

FEATURES

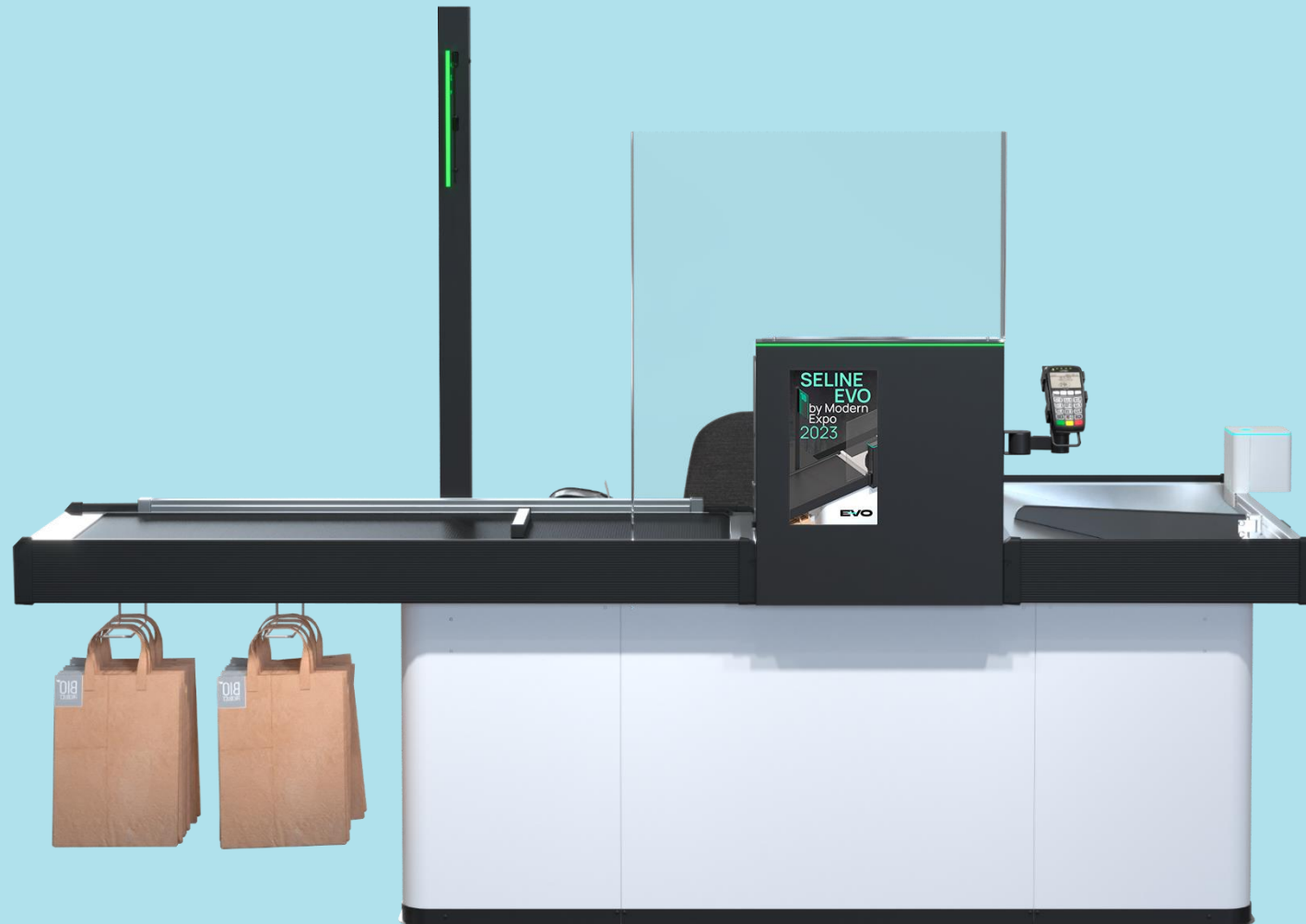

**MODULAR
DESIGN**



**UNIVERSAL
LEFT-RIGHT**

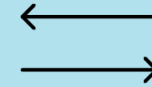

**DAMAGE
RESISTANT
PROFILE**



**LED
INDICATION**

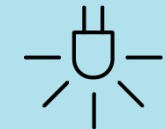

**PROMO
SCREEN**



**ACRYLIC
BARRIER**



STYLISH BUMPER PROFILE

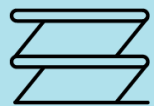

MATERIAL FLEXI PVC



DAMAGE RESISTANT



SCRATCH RESISTANT



MATTE SURFACE

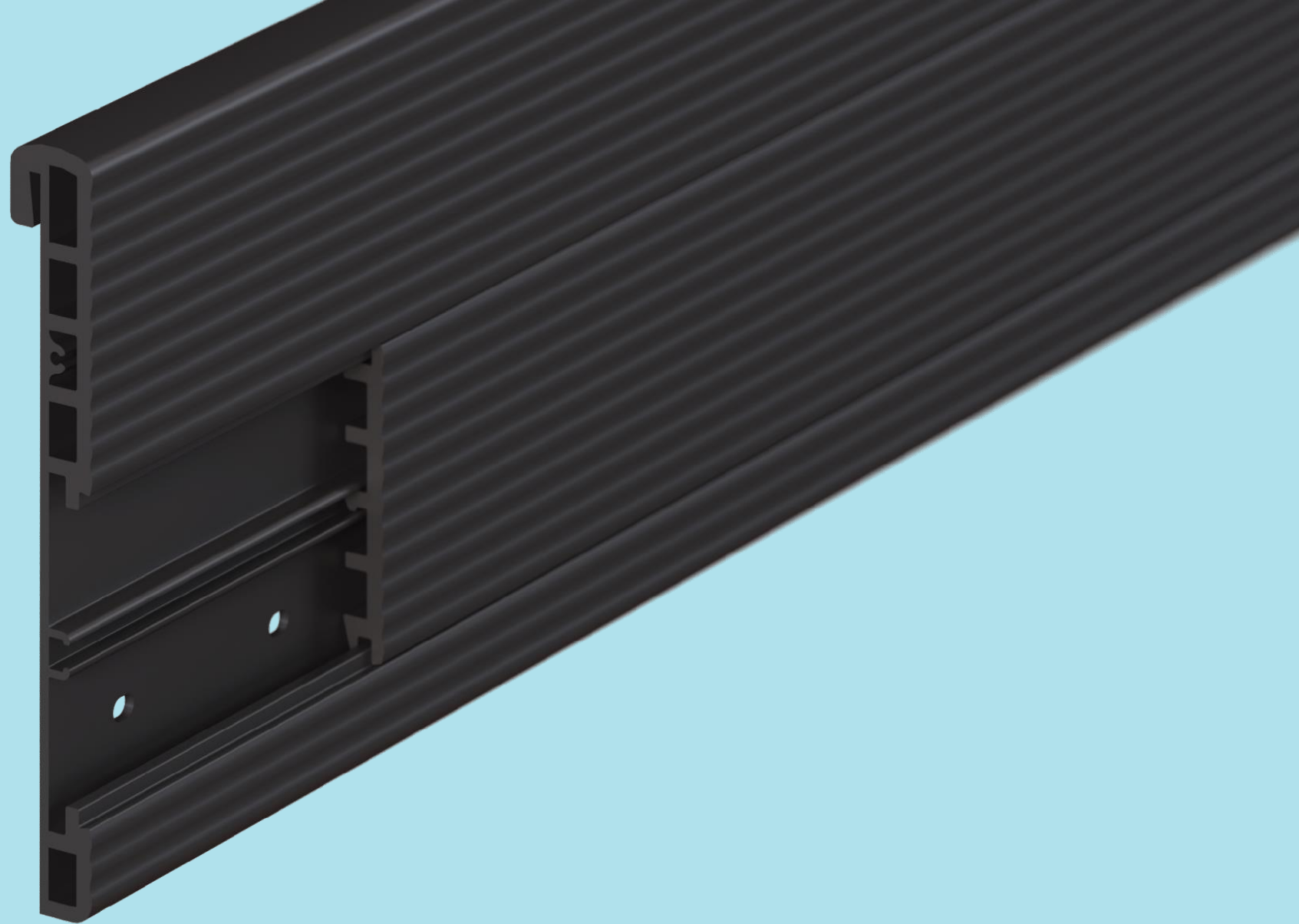

WIDE RANGE OF ACCESSORIES

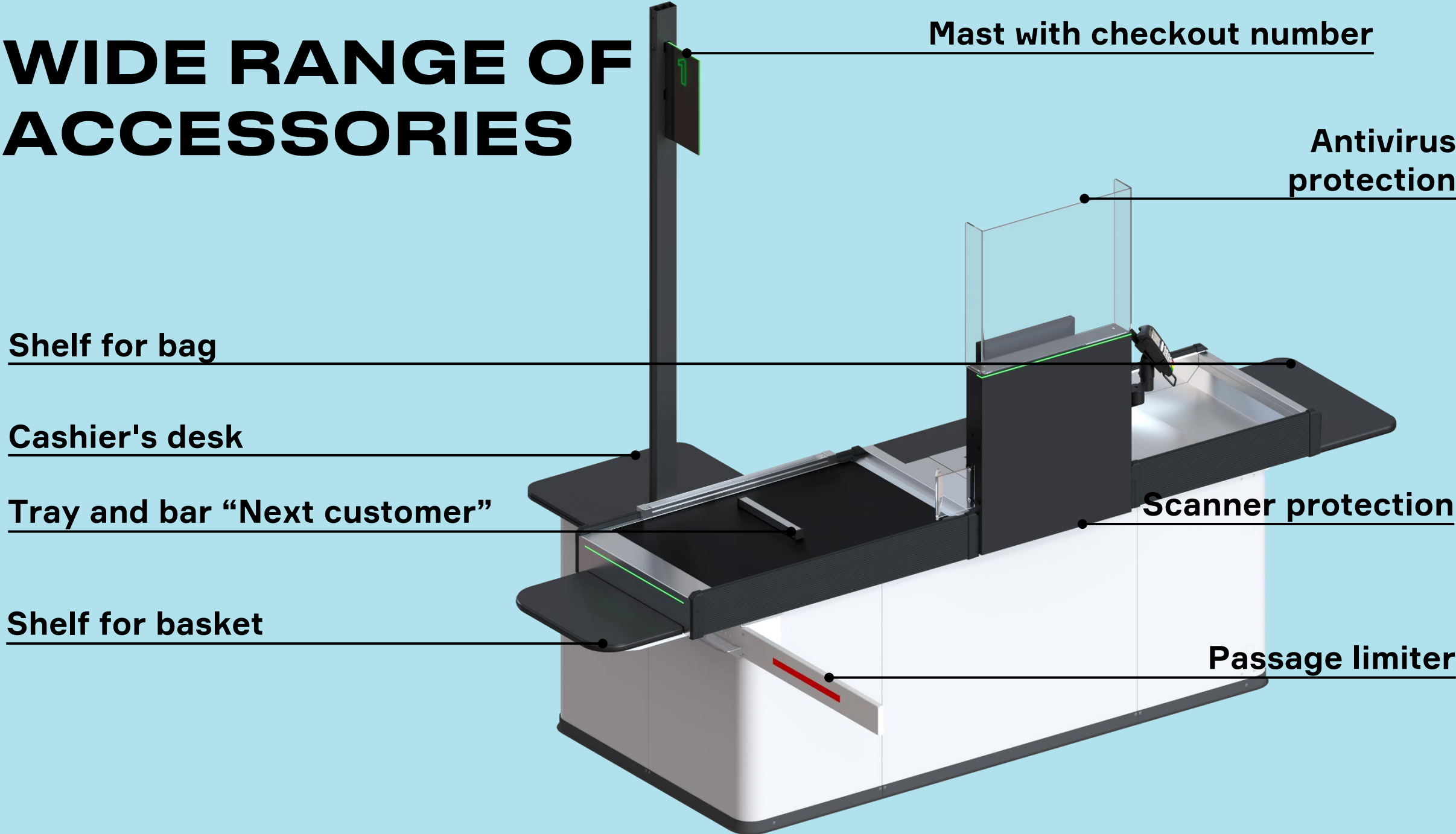

WIDE RANGE OF ACCESSORIES

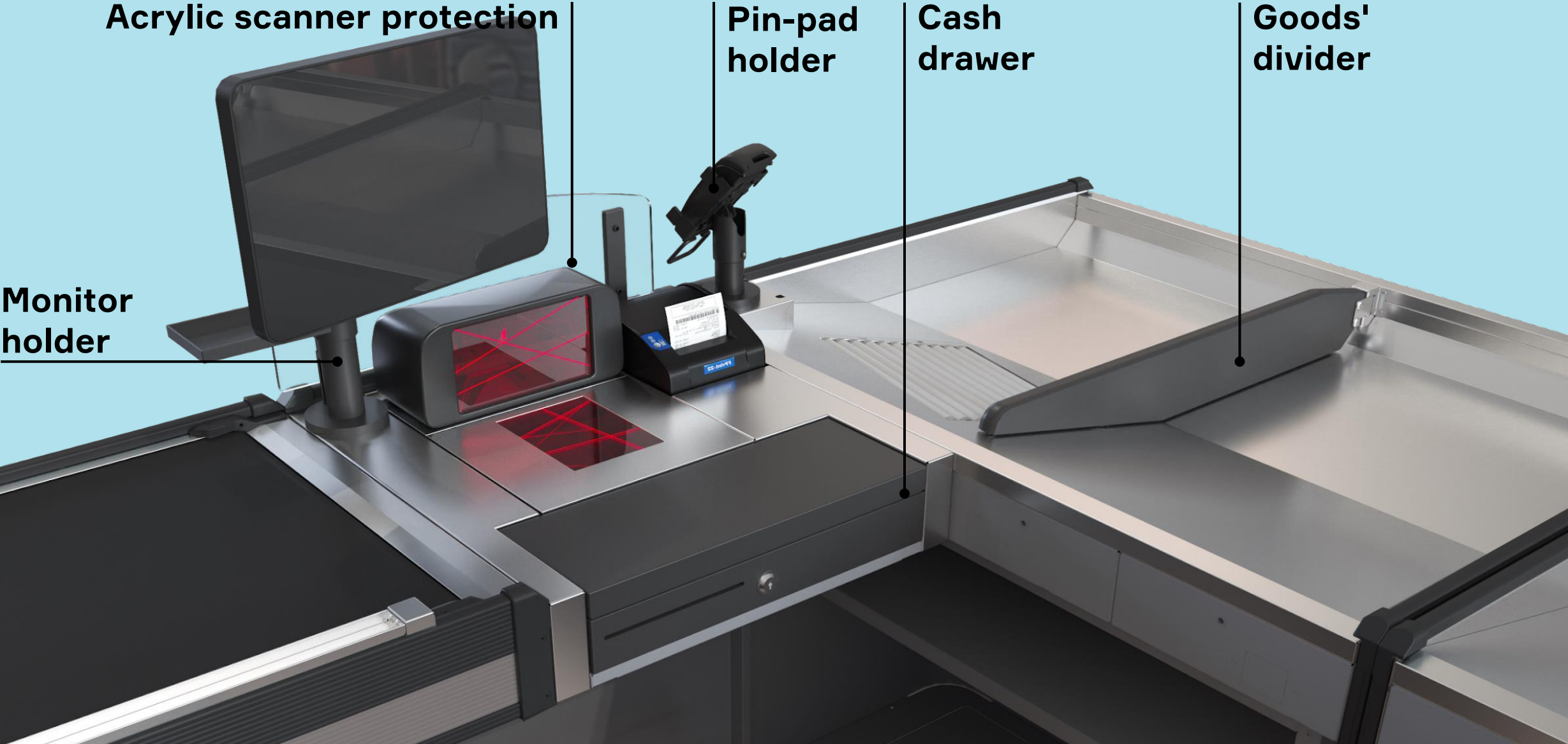

LED NAVIGATION

18

On the checkout number

On the scanner protection

On the transporter

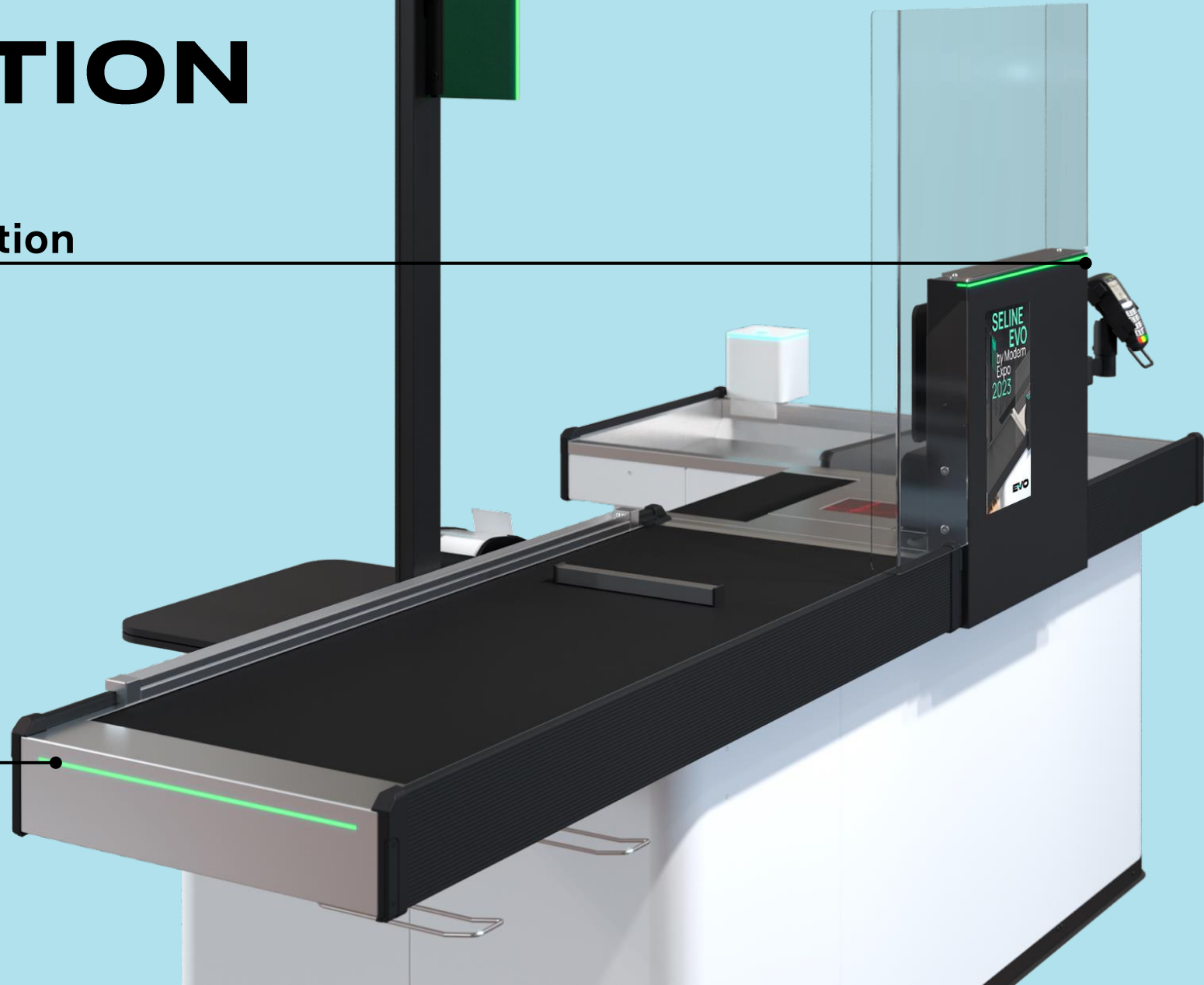

Combine **EVO** counter with **ROTO** self-checkout, which can work in traditional or self-service mode

All that is needed is to change the device orientation by 180° with a light movement



SCENARIO OF WORK WITH ROTO

1



The cashier serves customers in the traditional mode at the **EVO+ROTO checkout**

2



The number of visitors of the store is decreasing

3



The cashier rotates **ROTO** to **SELF-SERVICE** mode

4



Customers use **ROTO** in the **SELF-SERVICE** mode

5



The cashier fills the shelves with goods



Nowadays, it is extremely important to improve clients` checkout experience through digital technologies

Meet LUNA and LYRA - our beautiful and innovative self-checkouts that provide the highest quality of customer service

SELINE LUNA

Full-functional self-checkout, equipped with one or two weighting modules, stand for bags, holders for printer and pin-pad, as well as a scanner and LED indication

**15'6
screen**

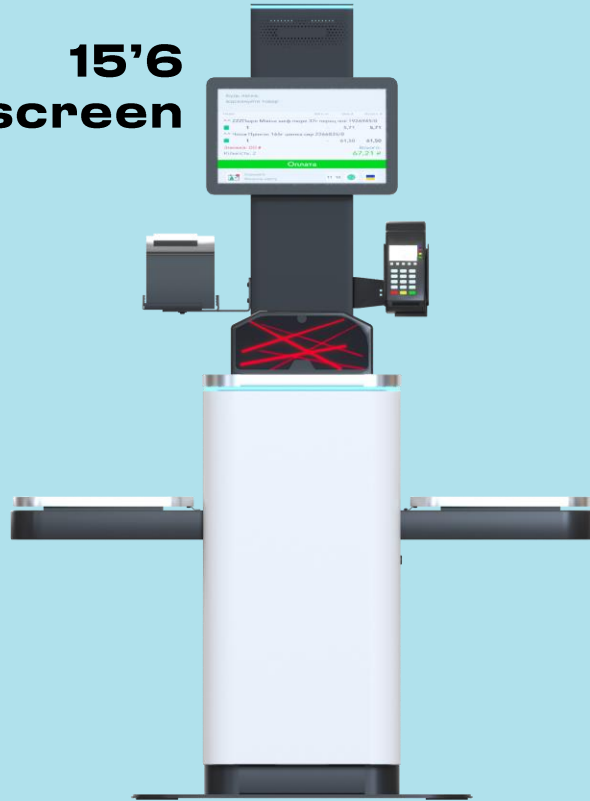

**21'5
screen**

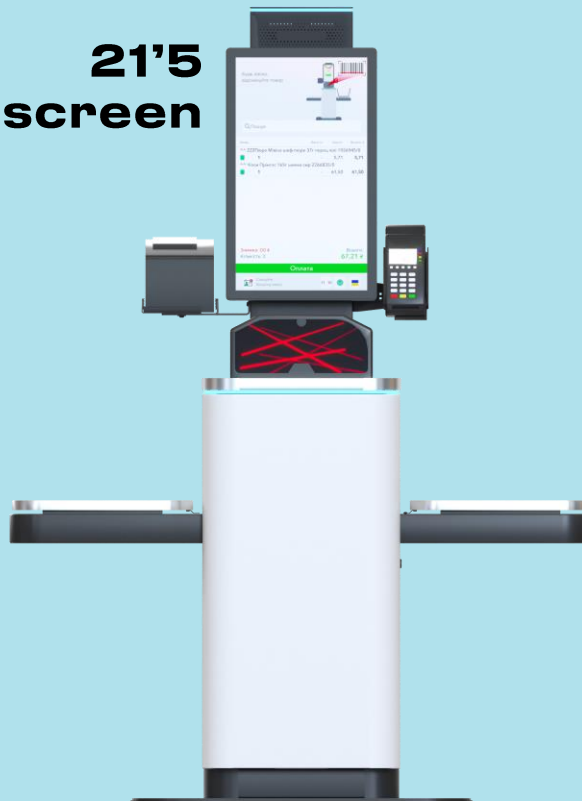

**2x
security
scales**

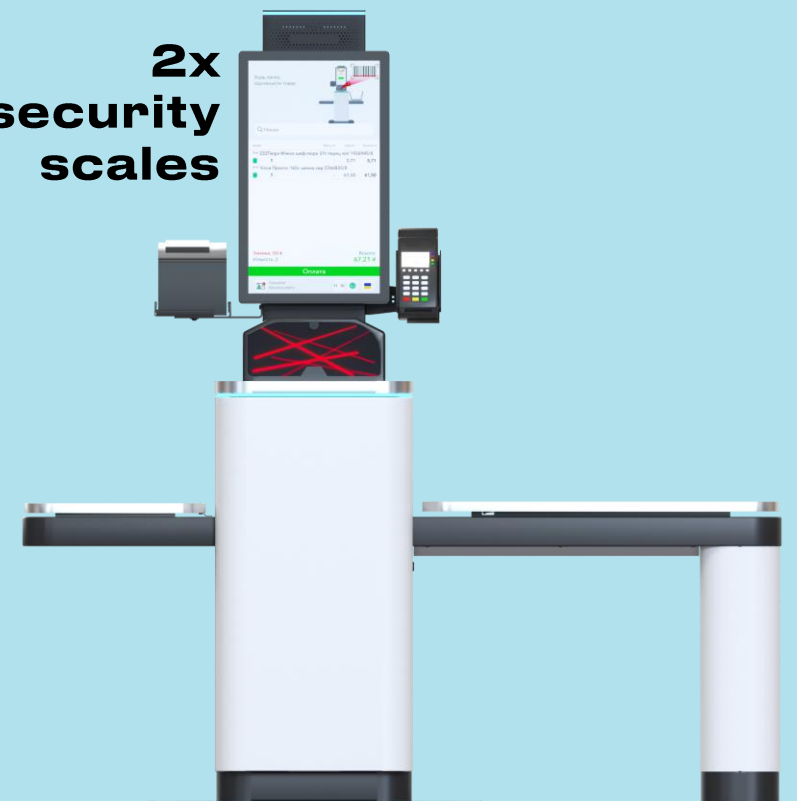

SELINE LYRA

**WALL
MOUNT**



**STAND
MOUNT**

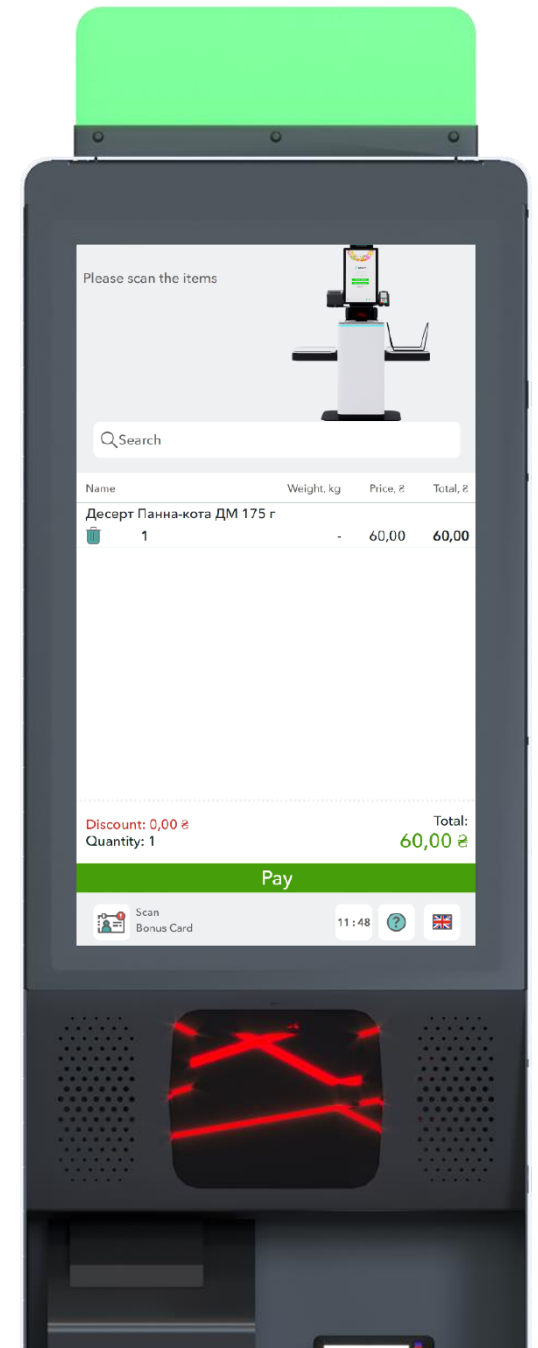
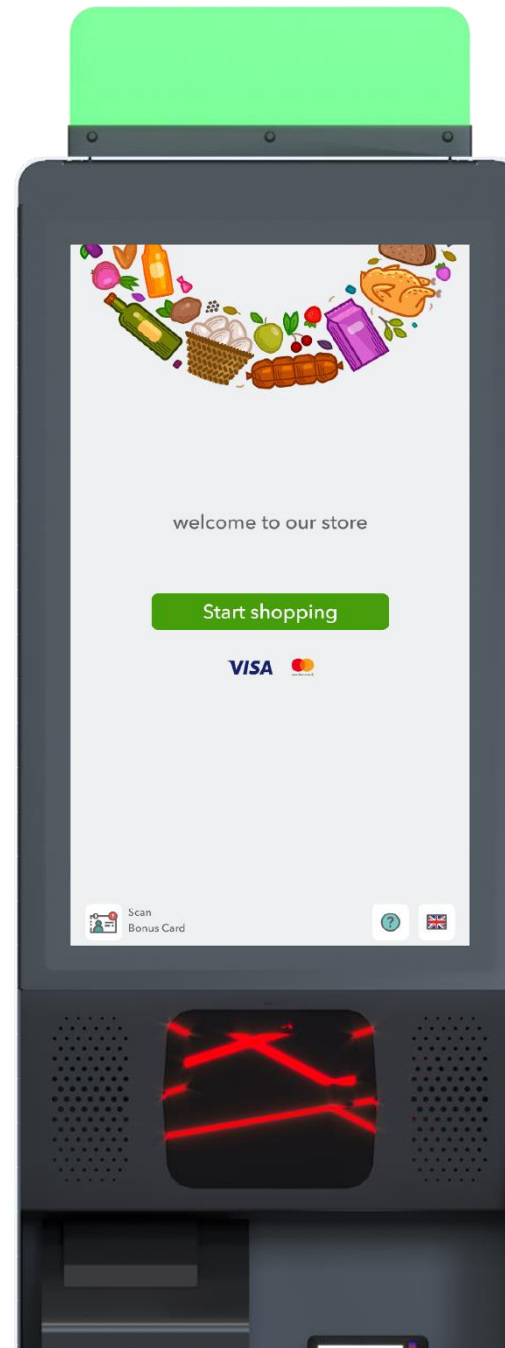

**TABLE
MOUNT**



An optimized-sized, ergonomic, and fast self-checkout, that provides an increase in functionality and capacity for even small retail spaces.

With modular software packages, Modern Expo provides a complete self-checkout ecosystem for retailers



SELF-CHECKOUTS

TECHNICAL SPECIFICATION

PROCESSOR

Intel i5-8250U

MEMORY

8GB DDR4

STORAGE

256GB

Solid state drive (SSD M2)

SCANNING

**Datalogic Magellan 3450VSI /
9300I**

Scanner-scales

TOUCH SCREEN

21,5/15.6 inch class A screen
Projective-capacitive touch
sensor

INTERVENTION

LED RGB status light, multicolor
Sound system 2x3W

SECURITY

Security scales

OPTIONS

Stand for bags
Hand scanner
Security scales (2 bag option)

OPERATING SYSTEM

Windows 10 IOT
Linux

CASE STUDIES

SILPO

UKRAINE

2021



ALJAZEERA

SAUDI ARABIA

2022



WARSHAVA

UKRAINE

2021



SELESTAT

FRANCE

2022



АТВ UKRAINE

2021



RYBAK

UKRAINE

2021



FORA

UKRAINE

2022



VESELKA

UKRAINE

2021



DMART

UKRAINE

2020



MODERN EXPO

Today we have become a platform bringing together leading professionals into powerful teams of **R&D, IT, retail design, engineering**, etc., working in synergy to create the perfect retail of the future by Modern Expo.

 **MINT**

[IT]

 **SQUARES**

[DESIGN]

 **ENGINEERING**

[MACHINERY]

WE CREATE
RETAIL NEW

MODERN EXPO has been a top company in creation of modern retail for more than 20 years.



We are convinced that modern retail is a phenomenon encompassing a multilevel system of obtaining goods with the ultimate consumer. Today, it's not just the physical store space, but also the solutions for E-commerce, warehouses, logistics and integrated supply chain.



Modern Expo is **9** high-tech
PRODUCTION UNITS specializing
in different types of equipment. Our
manufacture is one of the most powerful in the
world, we provide mass replication in roll-outs
and ensure meeting each of our products with
European safety and quality standards (EN and
FEM).

MODERN GEOGRAPHY

We supply our
products to more
than **75** countries

MODERN NUMBERS

2200 employees

83 500 m² production facilities

100+ dealers

MODERN WORLDS



watch here

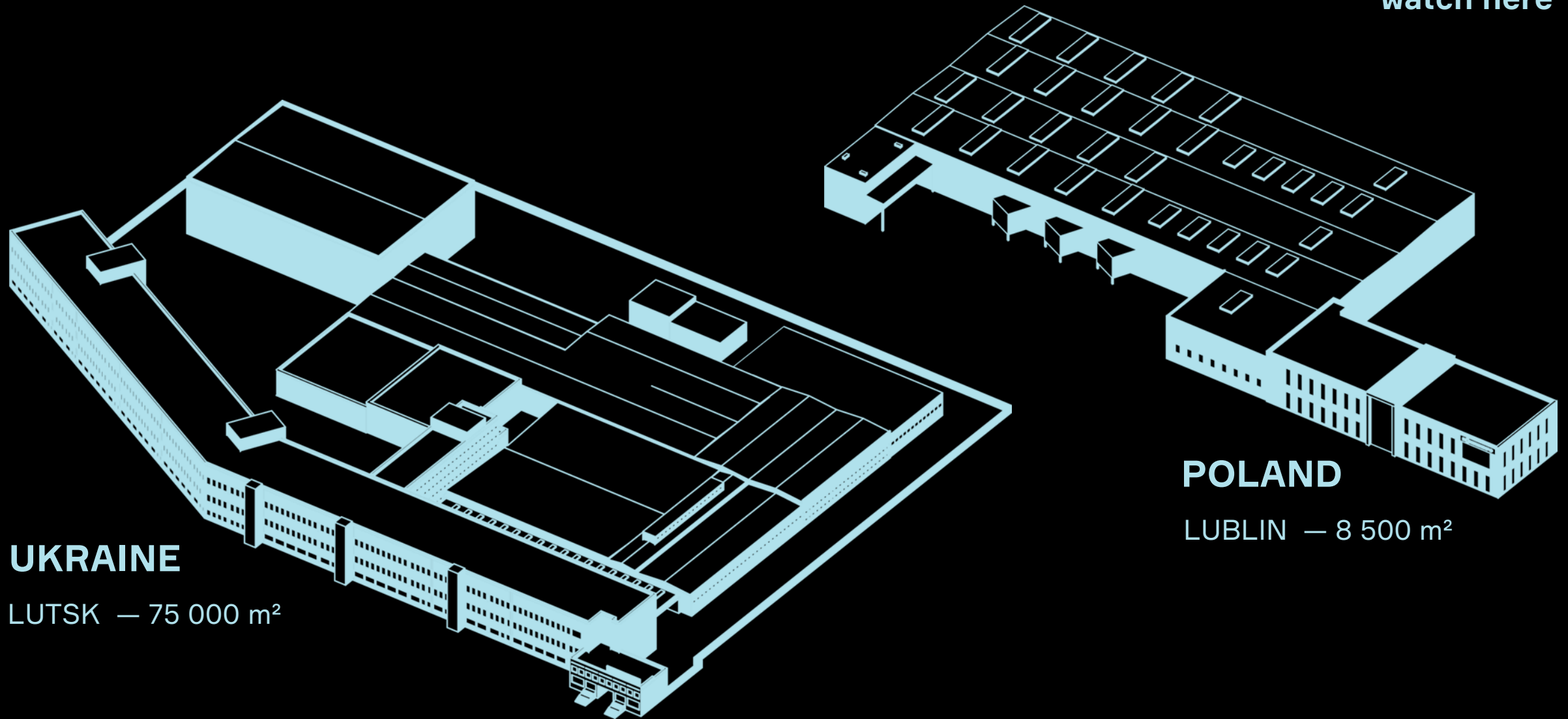

UKRAINE

LUTSK — 75 000 m²

POLAND

LUBLIN — 8 500 m²

MODERN CLIENTS

castorama -



Carrefour

allegro

WAITROSE



Intermarché

zabka



EPIЦEHTP®



SAMEDAY
yourway.

SPAR



profi

zlinic preturi mici

ATB

coop

أسواق التميمي
tamimi markets

ميدليات الدواء
al dawaa pharmacies
رعاية بلا حدود | Unlimited Care

REWE



METRO

نستو
NESTO
All that you need.

DOLLAR\$TORE
Mighty fine prices Every Day

araz

E.Leclerc

MIX
Mart

ROSSMANN

#WEAREMODERN

STAY IN TOUCH!
FOLLOW US HERE:

