

PULSAR

**CHECKOUT LINE
FOR CONVENIENCE
STORE**

M²DERN EXPO

Convenience stores became the most popular retail format for modern customers, thanks to the combination of accessibility, selection, speed, affordability, and convenient payment options. Usually, people visit convenience stores in a hurry, becoming open to impulse purchases

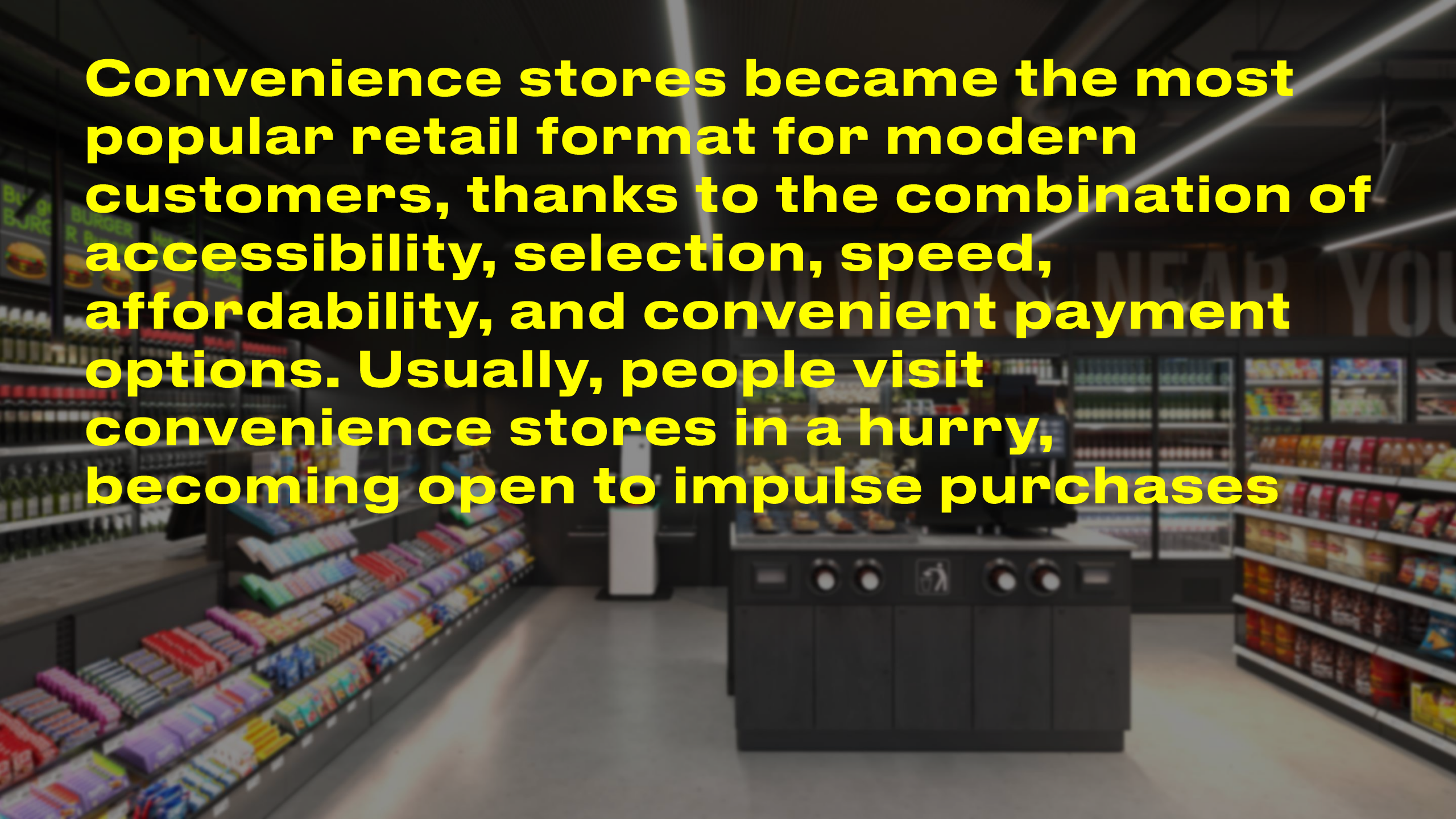

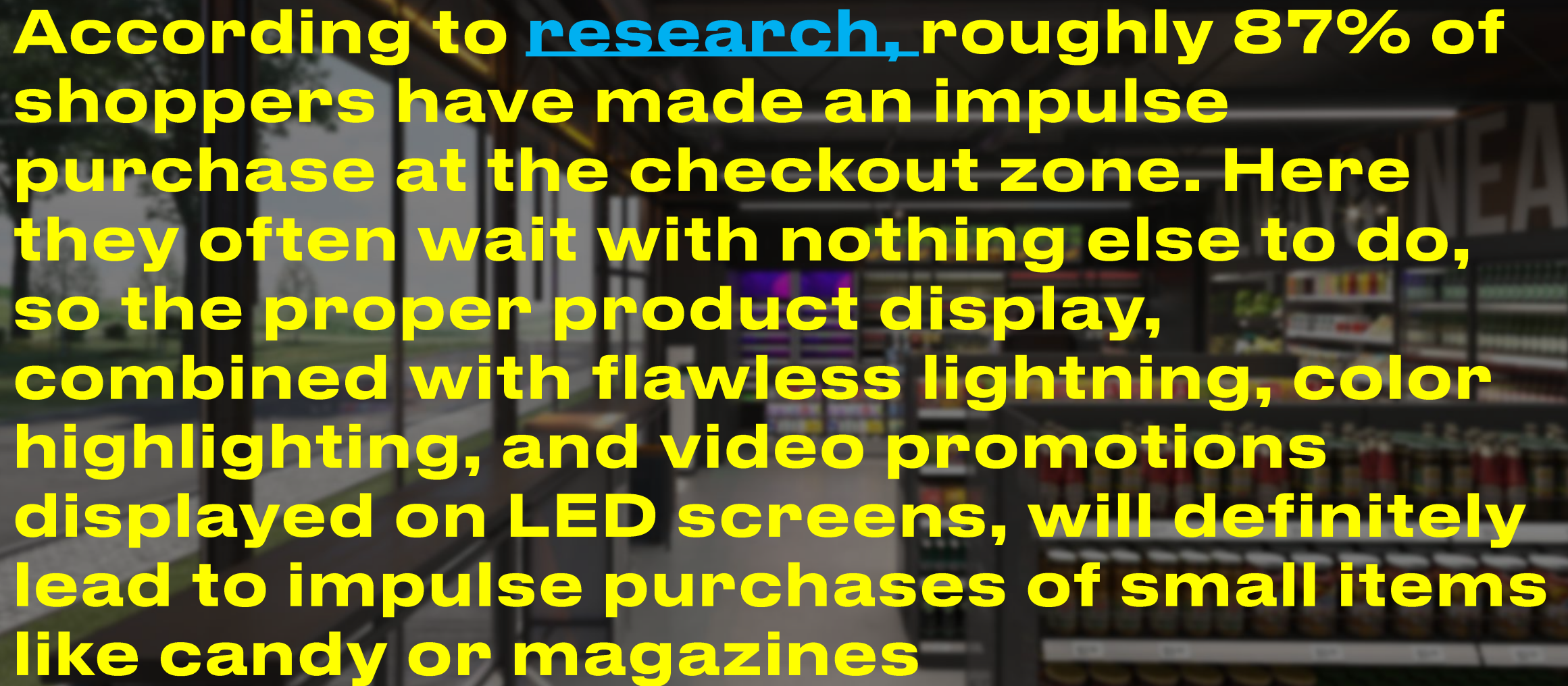

According to research, roughly 87% of shoppers have made an impulse purchase at the checkout zone. Here they often wait with nothing else to do, so the proper product display, combined with flawless lightning, color highlighting, and video promotions displayed on LED screens, will definitely lead to impulse purchases of small items like candy or magazines

CHECKOUT LINE PULSAR

is an ideal solution for a modern convenience store checkout area with multifunctional capabilities

The modular construction allows placing different configurations of counters, refrigerated cabinets, hot-dog modules, and even ROTO self-checkout in one line complementing it with multifunctional rear shelving solutions

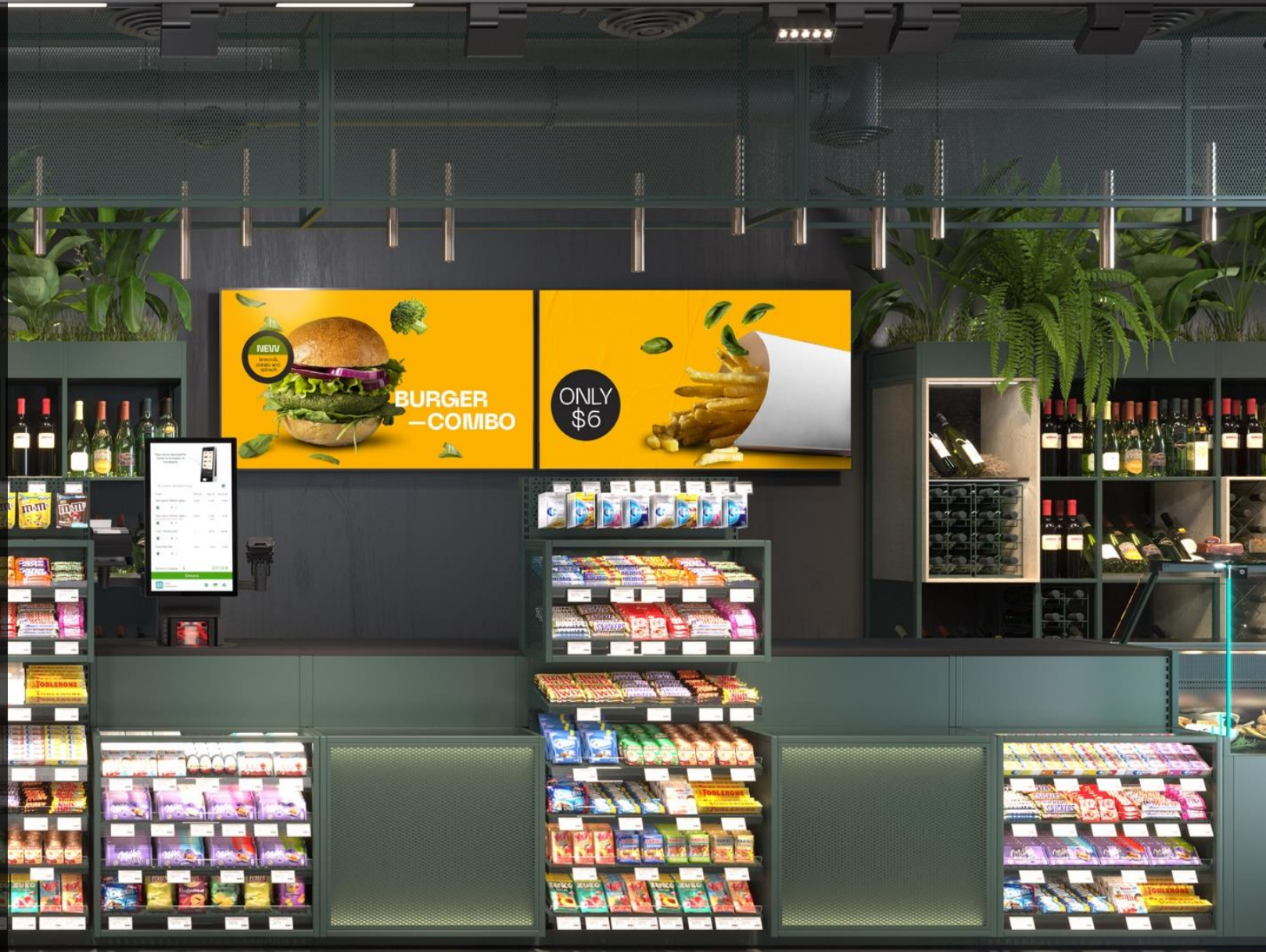

MODULARITY

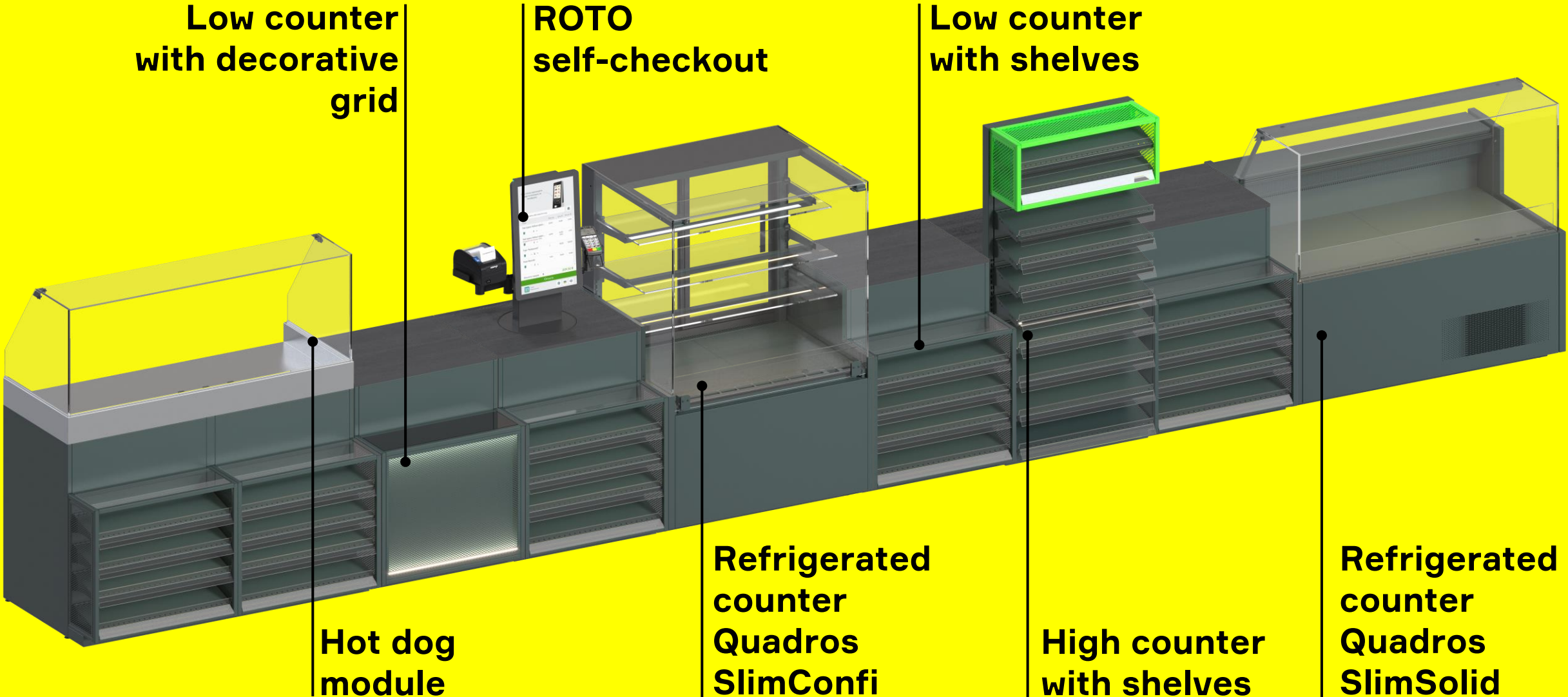

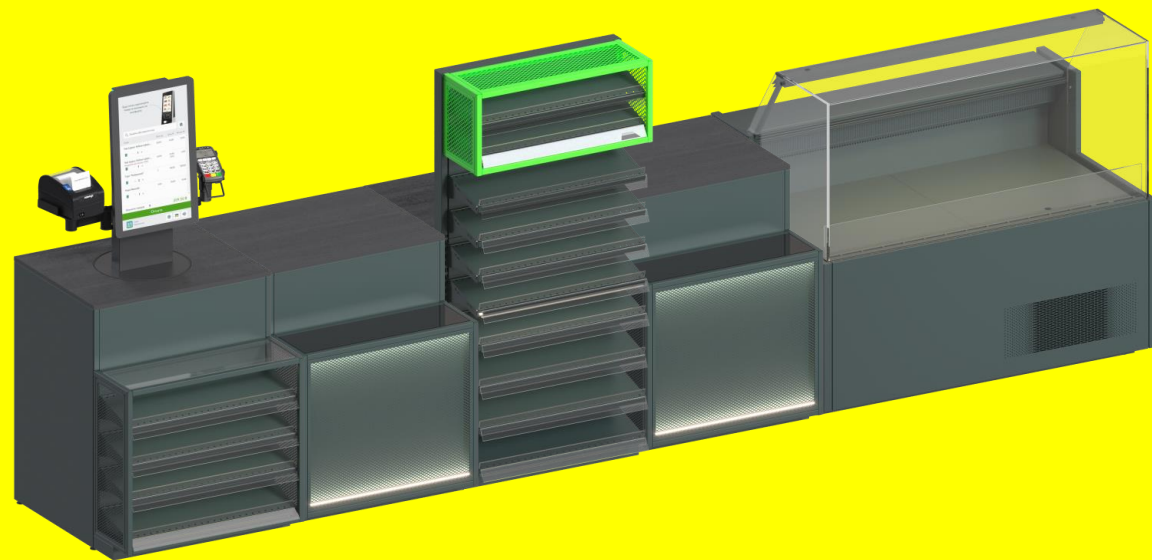
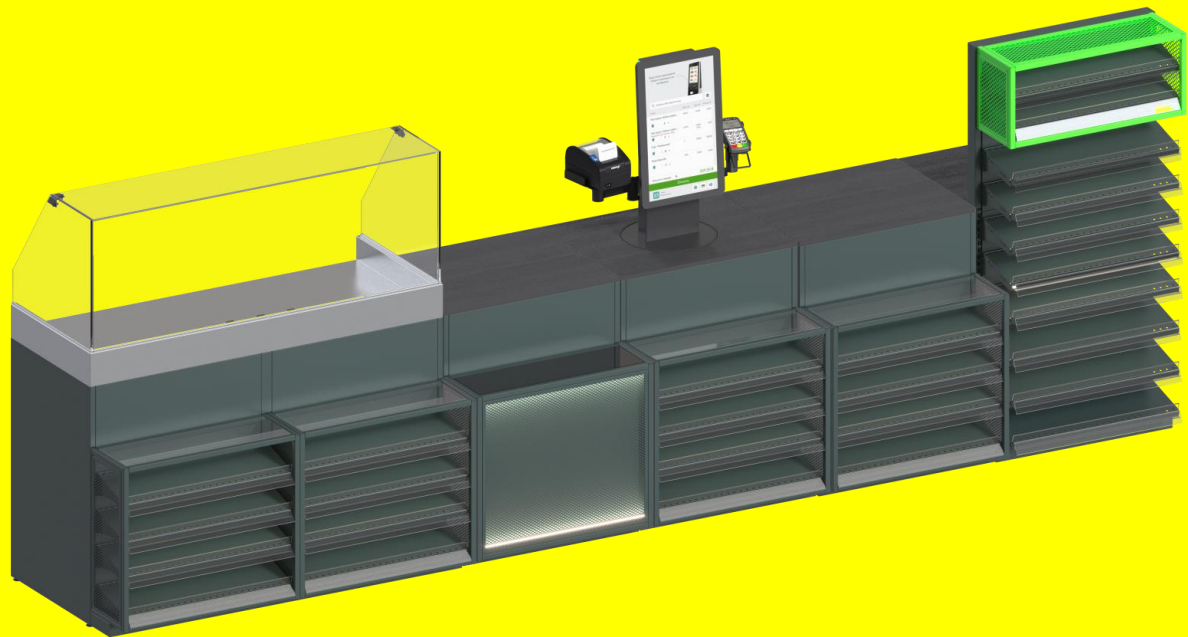

COUNTERS FRONT SIDE

Each counter can be supplemented with shelves or a decorative grid on the front side

Hot-Dog & Coffee
Super choice 6⁹⁹

Piece of Pizza
Take away 2⁹⁹

Burger Grill
Extra bacon 4⁹⁹

Burger & Cola
Less 50

PROMO FRAME integration focuses attention on particular products and increases cooperation with FMCG producers



COUNTERS REAR SIDE

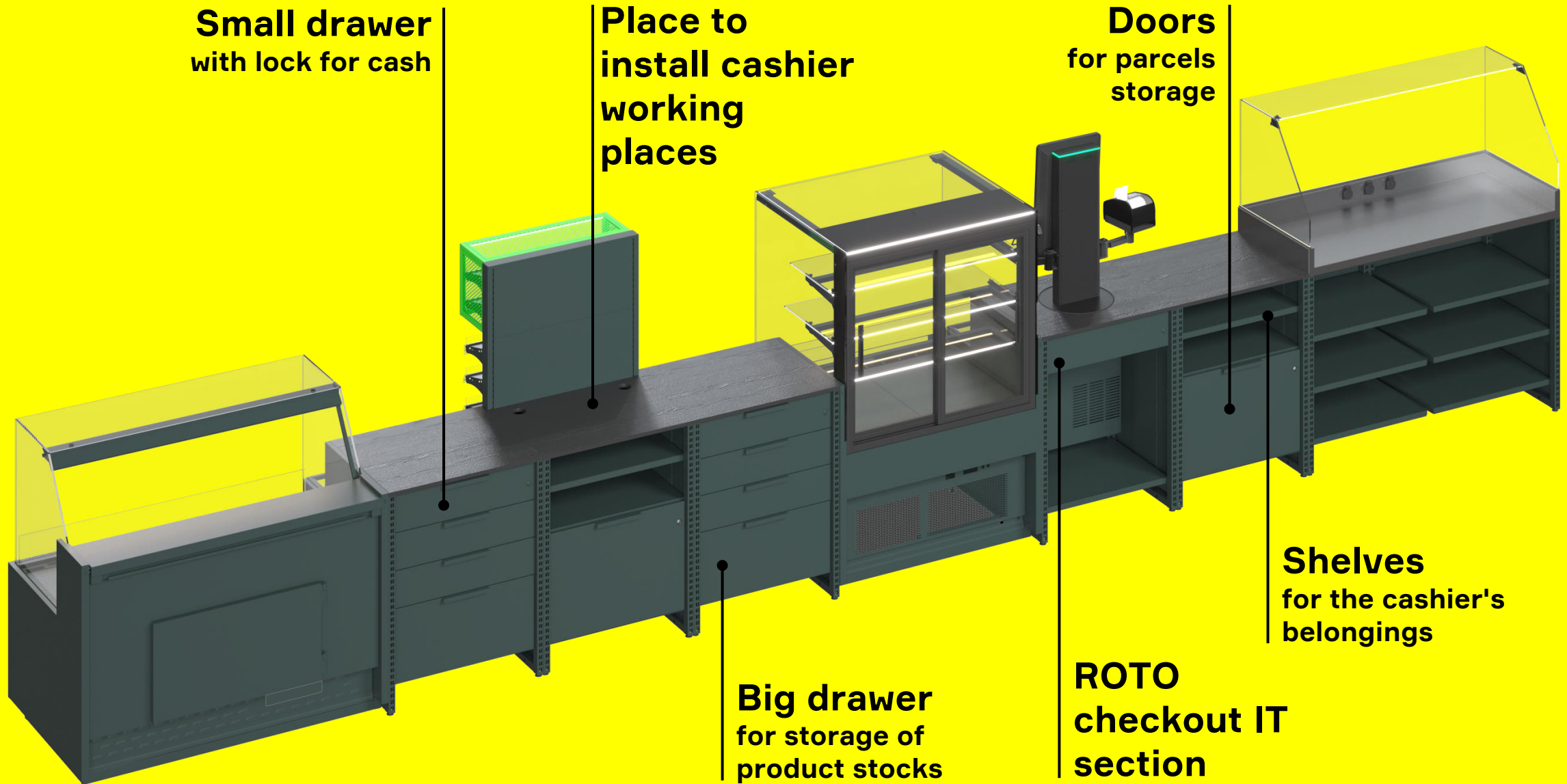



**SELINE
ROTO**
Rotated self-checkout ROTO is a universal device with the possibility of working in self-service mode or traditional mode with a cashier

Будь ласка,
відскануйте товар

Пошук

Товар	Відсканувати	Кількість	Ціна за одиницю	Всього за
ZZZПоре Міана шэф-поре 37г перец чілі 1926945/0		1	5,71	5,71
Маса Прінглс 165г шинка сир 2266835/0		1	61,50	61,50

Знижка: 00 ₴
Кількість: 2

Всього: 67,21 ₴

Оплата

Сканувати
Сторону кабу

11 10



SCENARIO OF WORK WITH ROTO

1



The cashier serves customers in the traditional mode at the ROTO checkout

2



The number of visitors to the store is increasing

3



The cashier rotates ROTO to SELF-SERVICE mode

4



Customers use ROTO in the SELF-SERVICE mode

5



During this time, the cashier is making hot dogs

QUADROS SLIMCONFI

Refrigerated counter specially designed to demonstrate and sale of confectionery. Equipped with glass shelves, providing optimal visibility of the product



QUADROS SLIMSOLID

**Compact
refrigerated counter
with improved
visibility, additional
understorage
volume, energy-
efficient solutions**

**Installation in one line
with PULSAR will
provide the perfect
solution for your
convenience store**



HOT DOG MODULE

The stainless steel countertop and glass protection on the customer side meet the food preparation standards, ensuring the best view of the hot dog cooking process

Unit dimensions allow placing grills for baguettes and sausages on the countertop, as well as a fridge for stock underneath the module



REAR CHECKOUT LINE

The area behind the cashier is harmoniously combined with the front line using shelving and promo frames with the same design as counters

Four promotional banners are displayed horizontally above the shelving units. From left to right: 1. 'Hot-Dog & Coffee' with a price tag of 'Super 2.99' and a 'Hiday' logo. 2. 'Piece of Pizza' with 'Take away' and a price tag of '2.99' and a 'Hiday' logo. 3. 'Burger Grill' with 'Extra bacon' and a price tag of '4€' and a 'Hiday' logo. 4. 'Burger & Cola' with 'Less price' and a price tag of '5.50€' and a 'Hiday' logo. Each banner features an image of the respective product.



Hot-Dog & Coffee
Super choice
6⁹⁹ €
Hidoy

Pizza
Take away
2 €
Hidoy

Burger Grill
Extra
4 €
Hidoy

Burger & Cola
Less price
5⁵⁰ €
Hidoy

MOBILE POST OFFICE

Special shelves for organizing the pick-up and drop-off of postal parcels help to transform the store into a mobile post office, providing additional value to the customer and increasing store traffic

A vertical stack of three digital displays showing floral patterns, positioned next to a shelving unit with various products.

A green-bordered shelving unit containing various bottles of alcohol, including whiskey and vodka.

A green-bordered shelving unit containing various bottles of alcohol, including beer and wine.

A grey metal shelving unit with multiple compartments, likely for organizing postal parcels.

A large shelving unit containing various boxes and bottles of alcohol, including wine and beer.

A dark-colored shelving unit containing various bottles of alcohol, including beer and wine.

Hot-Dog & Coffee
Super choice
6.99€
Hiday



Piece of Pizza
Take away
2.99€
Hiday



Burger Grill
Extra bacon
4€
Hiday



Burger & Cola
Less price
5.50€
Hiday



**PROMO
SCREENS**
Bright UHD 4K
promo screens
behind shelvings
help to focus
visitors' attention
on the most
profitable offers



Hot-Dog & Coffee
Super choice **6.99€**
Hiday

Piece of Pizza
Take away **2.99€**
Hiday

Burger Grill
Extra bacon **4€**
Hiday

Burger & Cola
Less price **5.50€**
Hiday

LED advertising panels with floral graphics and product displays.

Shelving line for tobacco and wine products, featuring LED lighting and advertising panels.

TOBACCO BACKWALLS
A worthwhile addition for the shelving line, with LED lighting and advertising panels

Green-bordered display area for tobacco products, including brands like Jaxx and Black.

Wine product labels including Maison Blanche, Gancia, Dom Perignon, Caymus Vineyards, Sassicata, and Petrus.

DIMENSIONS

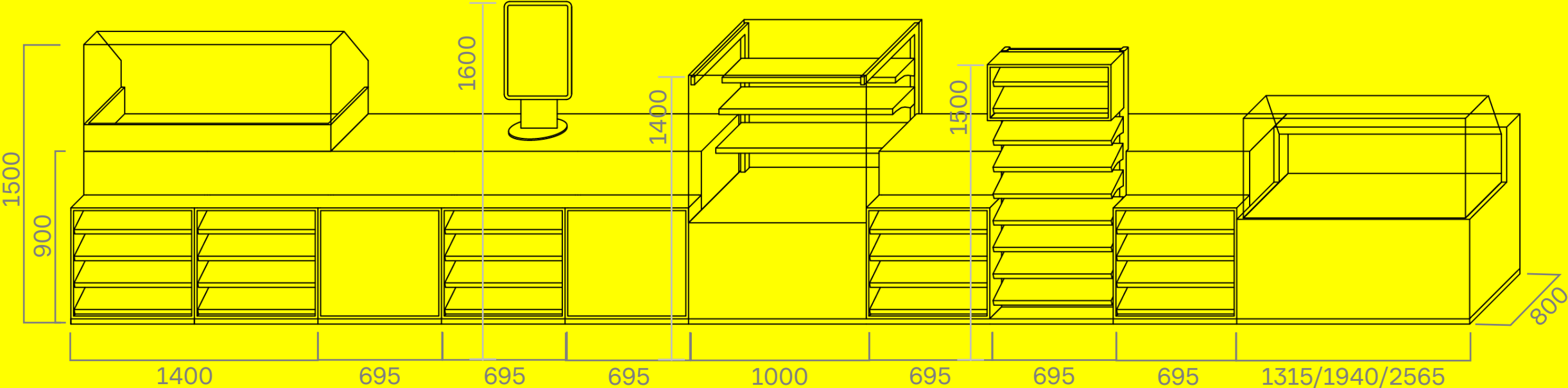

DIMENSIONS

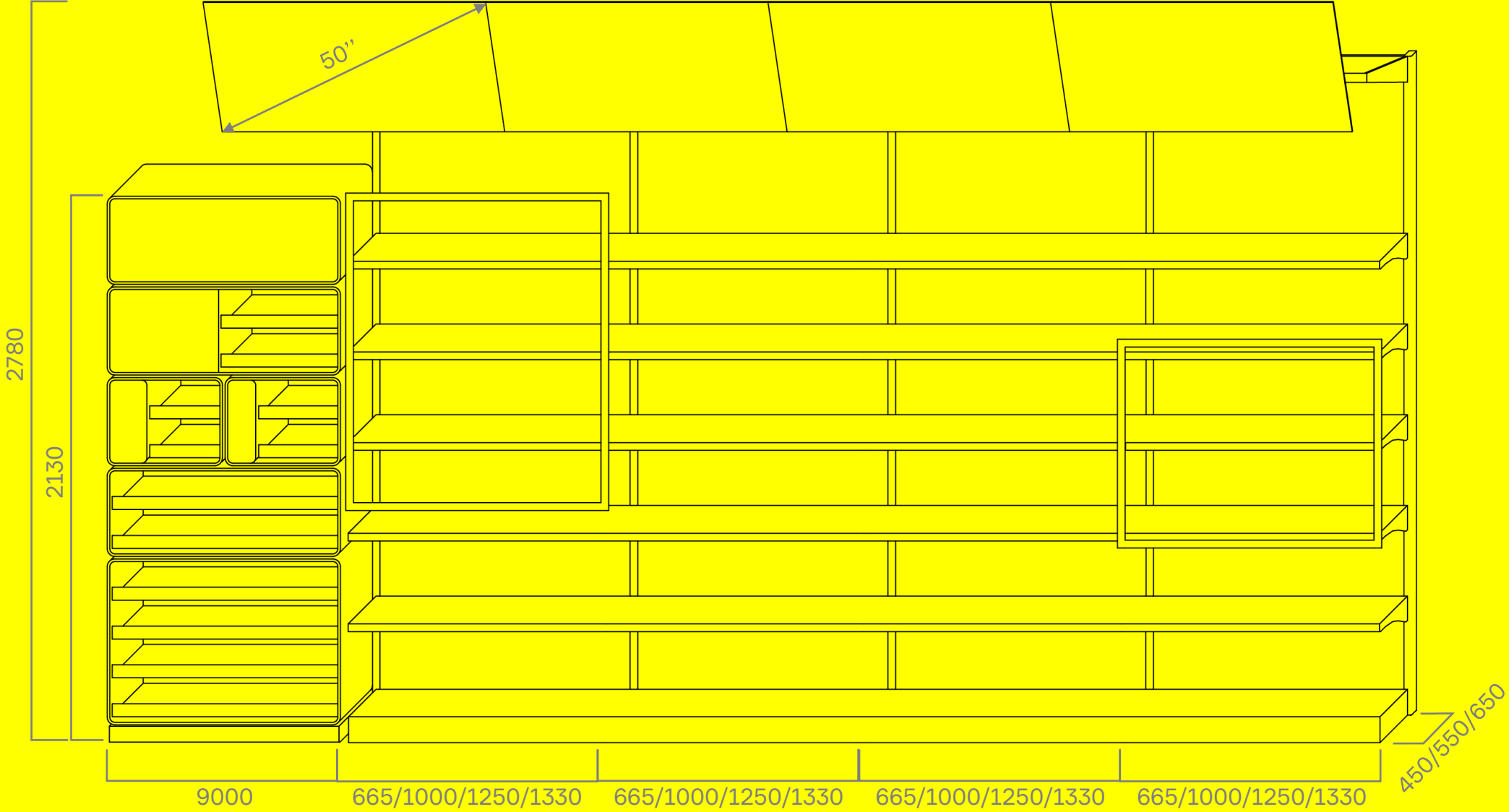

TECHNICAL SPECIFICATION

GENERAL

Power supply
220 V

LED Lighting
4000 K

COUNTERS

Countertop
**MDF Egger Black
Forest 16 mm**

SELINE ROTO

Processor
Intel i5-8250U

Barcode Scanner
**Datalogic Magellan
3450VSI**

Touch screen
**21,5" class A
screen
Projective-
capacitive touch
sensor**

REFRIGERATORS

Temperature class
3H1(+1...+10 °C)

Refrigerant
R290

Refrigeration unit
Plug-in

EuroCIS 2022

Manage your
Inventory
Effectively

POINT Mobile

SMART
BEYOND
RUGGED®

POINT Mobile

Boost your
Front Store
Operations

HÖRMANN
Logistik

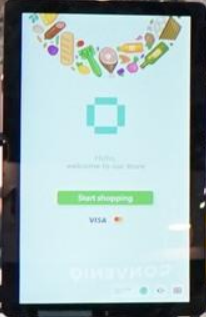

POINT Mobile

MODE
RUN
EXPO





Manage your
Inventory
Effectively

POINT Mobile

BEYOND
RUGGED®

POINT Mobile

Boost your
Front Store
Operations

MODERN
EXPERIENCE

CONVENIENCE



Konditionsmanagement und
Planungsrechnung
Logitech Automaten

Manage your
Inventory
Effectively

POINT Mobile

MODERN
EXPO
MODERN EXPO

MODERN
EXPO



ABOUT US

MODERN EXPO

Today we have become a platform bringing together leading professionals into powerful teams of **R&D, IT, retail design, engineering**, etc., working in synergy to create the perfect retail of the future by Modern Expo.

 **MINT**

[IT]

 **SQUARES**

[DESIGN]

 **ENGINEERING**

[MACHINERY]

WE CREATE
RETAIL NEVER

MODERN EXPO has been a top company in creation of modern retail for more than 20 years.



We are convinced that modern retail is a phenomenon encompassing a multilevel system of obtaining goods with the ultimate consumer. Today, it's not just the physical store space, but also the solutions for E-commerce, warehouses, logistics and integrated supply chain. Therefore, one of the leading directions of our work is developing products and services for the last mile, with a focus on parcel lockers solutions.



**Modern Expo is 9 high-tech
PRODUCTION UNITS specializing
in different types of equipment. Our
manufacture is one of the most powerful in the
world, we provide mass replication in roll-outs
and ensure meeting each of our products with
European safety and quality standards (EN and
FEM).**

MODERN GEOGRAPHY

A stylized map of Europe and the Middle East, rendered in white outlines on a black background. The map shows the outlines of countries and major cities. Several cities are marked with a small white dot and labeled in white capital letters: LONDON, PARIS, BERLIN, WARSAW, LUBLIN, LUTSK, KYIV, and DUBAI. The text 'MODERN GEOGRAPHY' is written in large, bold, white capital letters at the top left of the image.

We supply our
products to more
than **75** countries

MODERN NUMBERS

2200 employees

83 500 m² production facilities

100+ dealers

MODERN WORLDS



watch here

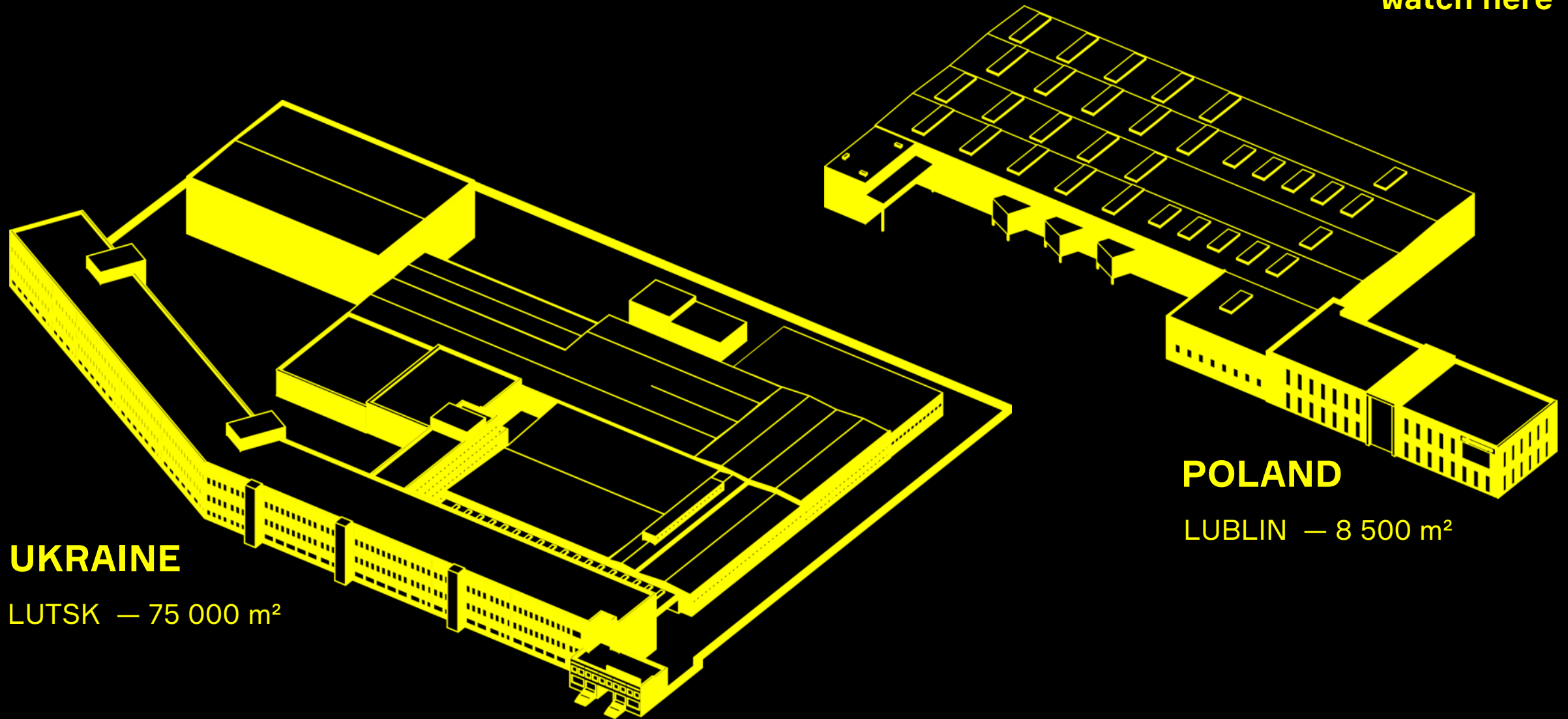

UKRAINE

LUTSK — 75 000 m²

POLAND

LUBLIN — 8 500 m²

MODERN CLIENTS

castorama



Carrefour

allegro

WAITROSE



Intermarché

zabka



SAMEDAY
yourway.

SPAR



ATB

coop

أسواق التميمي
tamimi markets

صيدليات الدواء
al dawaa pharmacies
رعاية بلا حدود | Unlimited Care

REWE



CONAD

نستو
NESTO
All that you need.

DOLLAR\$TORE
Mighty fine prices Every Day

araz

E.Leclerc

MIX
Mart

ROSSMANN

#WEAREMODERN

STAY IN TOUCH!
FOLLOW US HERE:

