

M²DERN EXPO

FRUITS & VEGETABLES

#newretail equipment

**GRE
ORA**

Impression

of an open market inside

Welcome to the new Greora space, a space where emotions and impressions are created for visitors, where active interaction between them is realized; to the space that engages customers and awakes their archetypal experience of looking for the freshest and the most attractive vegetables, fruits and greens; makes customer a hunter, walking between the shopping rows and picking up the best.

Greora is more than equipment. It suggests different solutions that reassemble open markets and implement an atmosphere of natural spaces – gardens and parks. It creates various mood messages for purchasing, communication, and experience exchange.

Effective design, modular system, easy transformation capabilities, and cascading product layouts enable Greora to perform the boldest ideas, demonstrate products and, at the same time, to engage the customer.

Dynamic interaction between concise lines and authentic exposition of fruits and vegetables creates harmony, radiates optimism, changes perception of multifunctional store, and opens new opportunities for success.



Greora family

Comprehensive presentation of vegetables and fruits

Greora family consists of 5 main kinds of modules and wide range of additional accessories, that give plenty of abilities to create various customized designs.

The bearing function is provided by a light square tubular framework.

Shelves may be conveniently replaced and rearranged for novelty effect.

Mobile modules are equipped with reliable wheels.

An additional audio unit guides attention and engages your customers with sounds of nature as well.

Greora may transform into a powerful cross-selling and educational tool, creating a great impulse to buy. Transformation possibilities of equipment into areas of workshops and lectures allow to reimagine your fruit and vegetable area into a magnet for visitors.

- > Variable
- > Pop-up solution
- > Cascading presentation
- > Modular design for size roll-out
- > Easy reconfiguration
- > Cross-selling capabilities
- > Sound visitors engagement
- > Lightweight construction
- > Pool of accessories for customized presentation
- > Contrasted authentic colors as a standard
- > Indoor usage

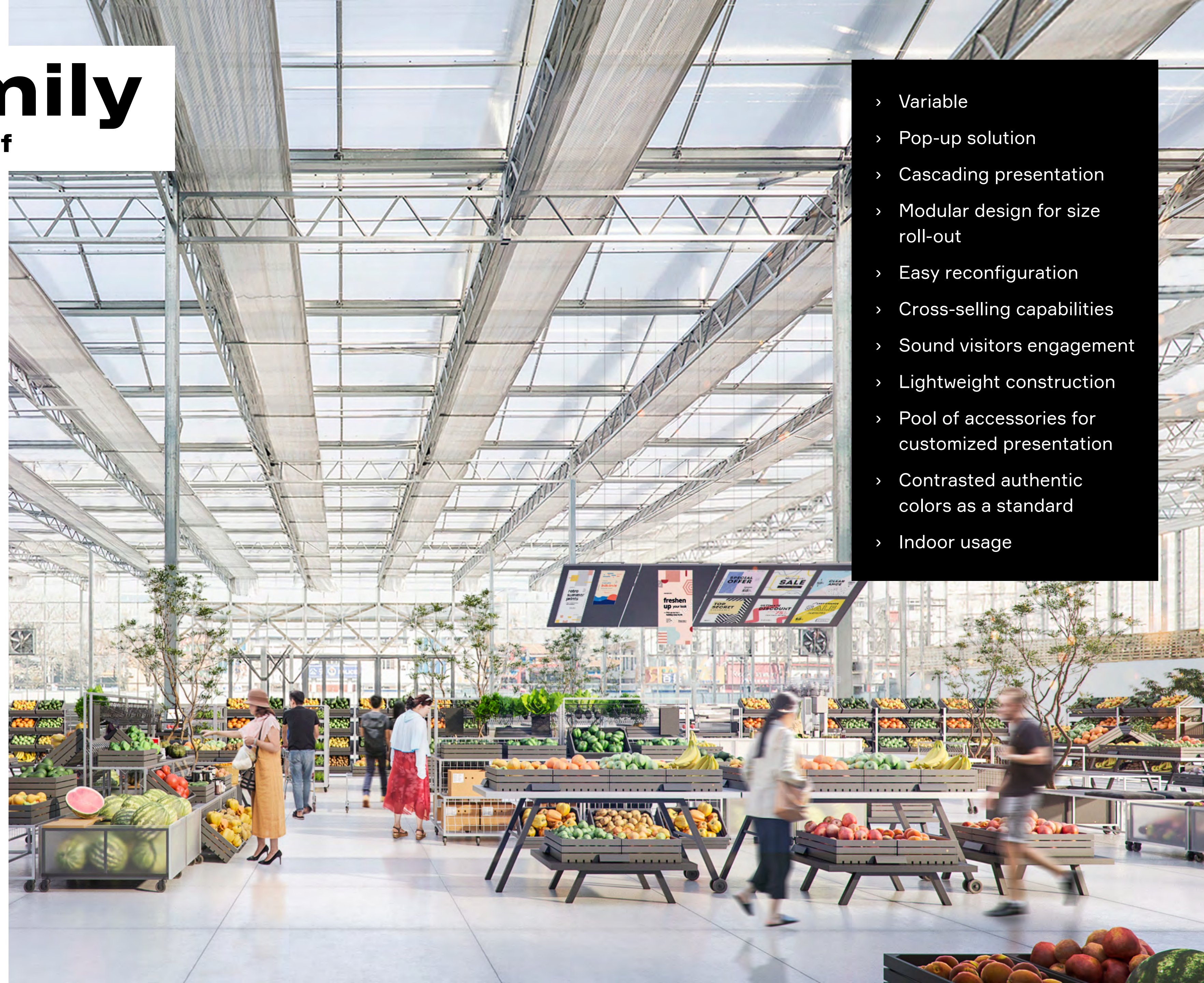

Stairs

Stepped shelves display with sound module

Storey

3-storey shelves display with sound module

Plateau

Low platform for 2-level exposition with sound module

Click the name to get details

Trapez

Layered and easy-to-modify expositions tables

Box

Low bargain double assignment baskets



Spaces

From a convenient city store to large fresh markets

Greora's modules are very versatile and can be quickly reconfigured, forming new landscapes for any format and allowing the most optimal use of retail space.

Can look minimalistic or create a dynamic interior, depending on the configuration and accessories used.

8 types of goods can be placed on only 0.5 m² of retail space.

Shop in shop

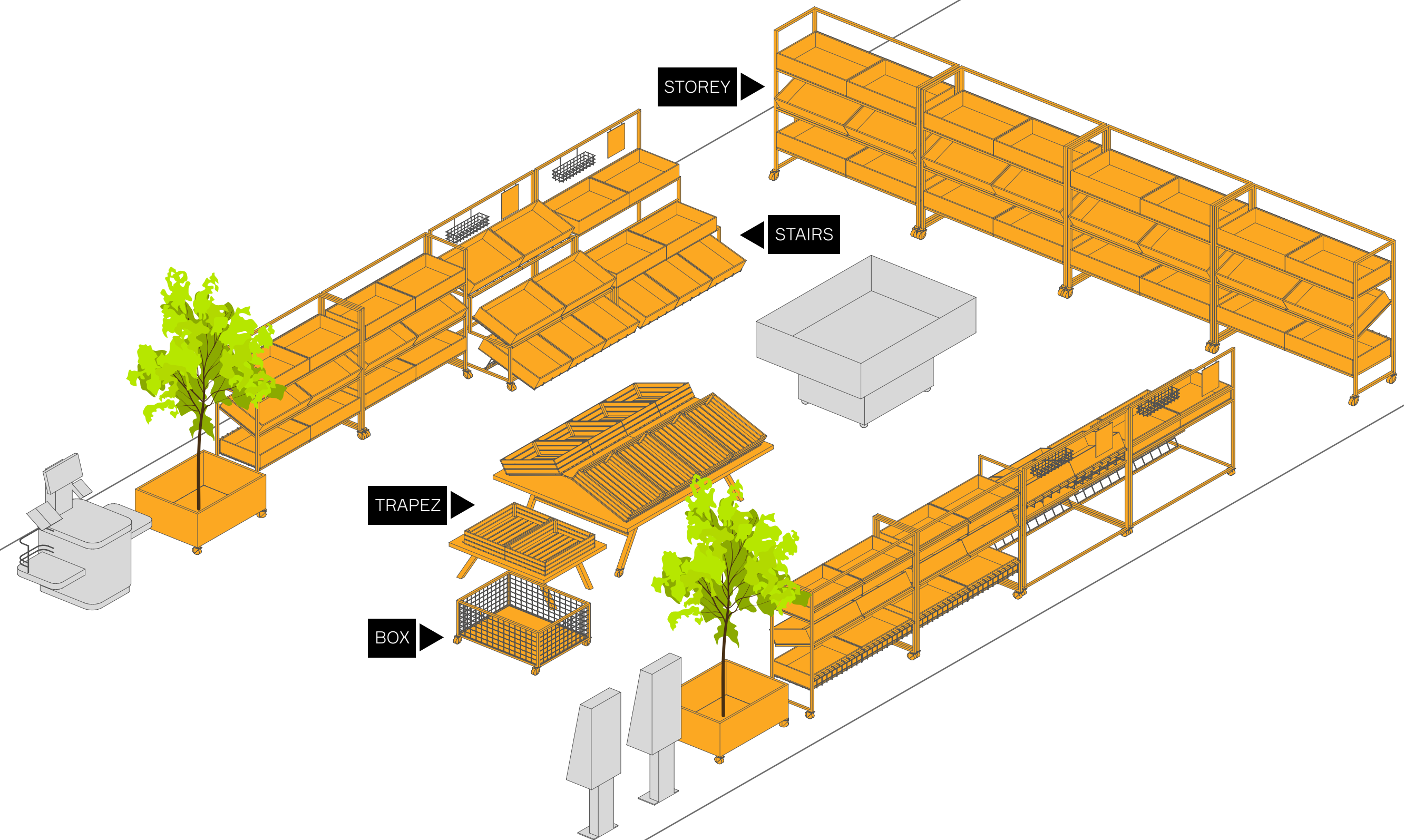

Convenience Store

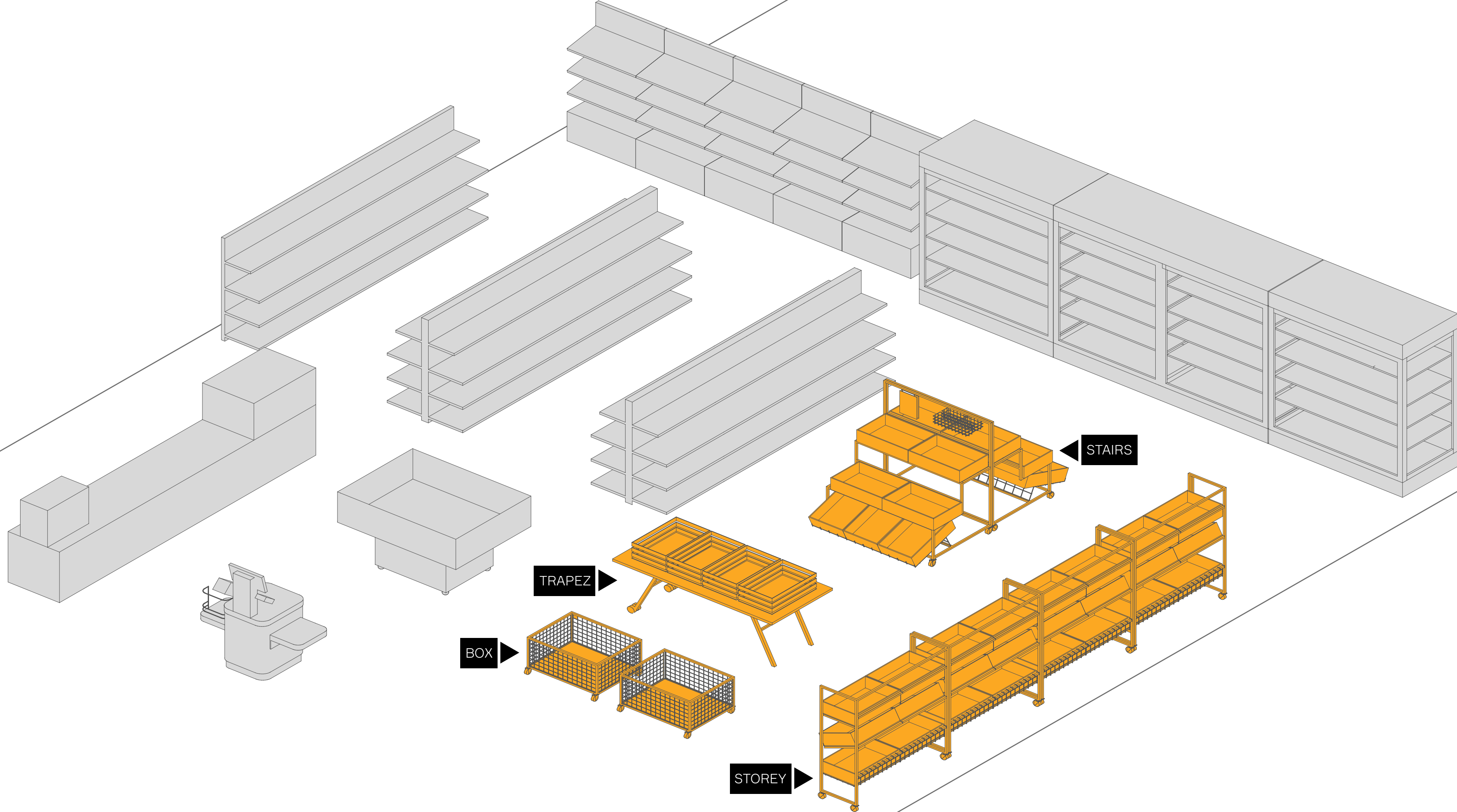

Hyper- / Supermarket

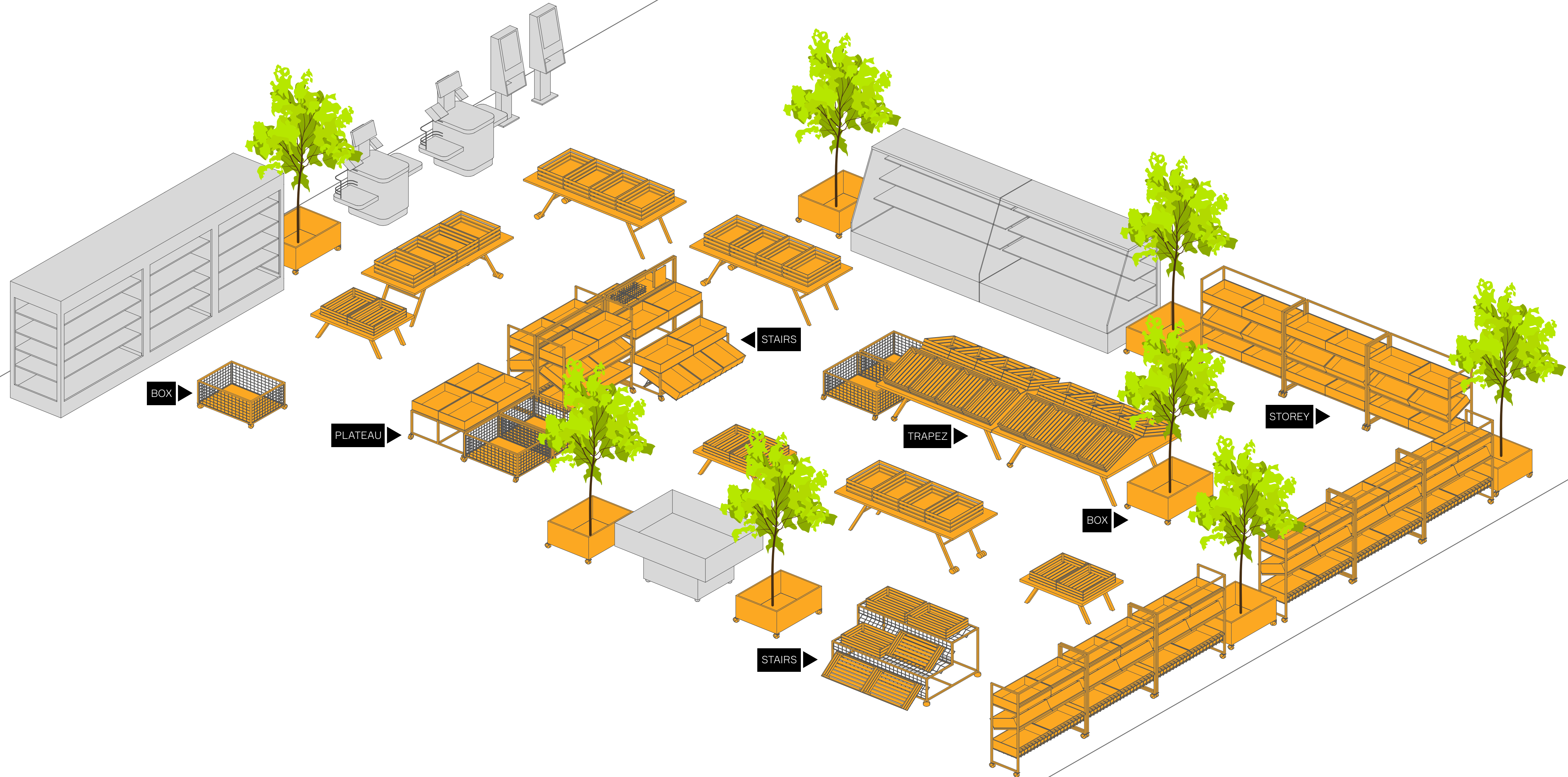

Stairs

Stepped shelves display with sound module

Stairs to your sound continuous presentation of fruits and vegetables

Size

1250x820x1478

Materials

metal square pipe

metal sheet

wire

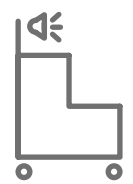

Sound module

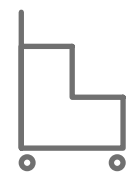

Cascading exposition



Additional stock level

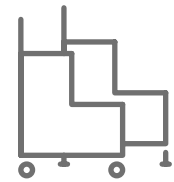

Mobile / stationary



Folding frame base

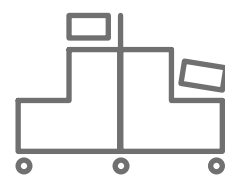

Wall / island unit



Horizontal / vertical arrangement of container



Customize your Stairs

Examples of sets

BASIC

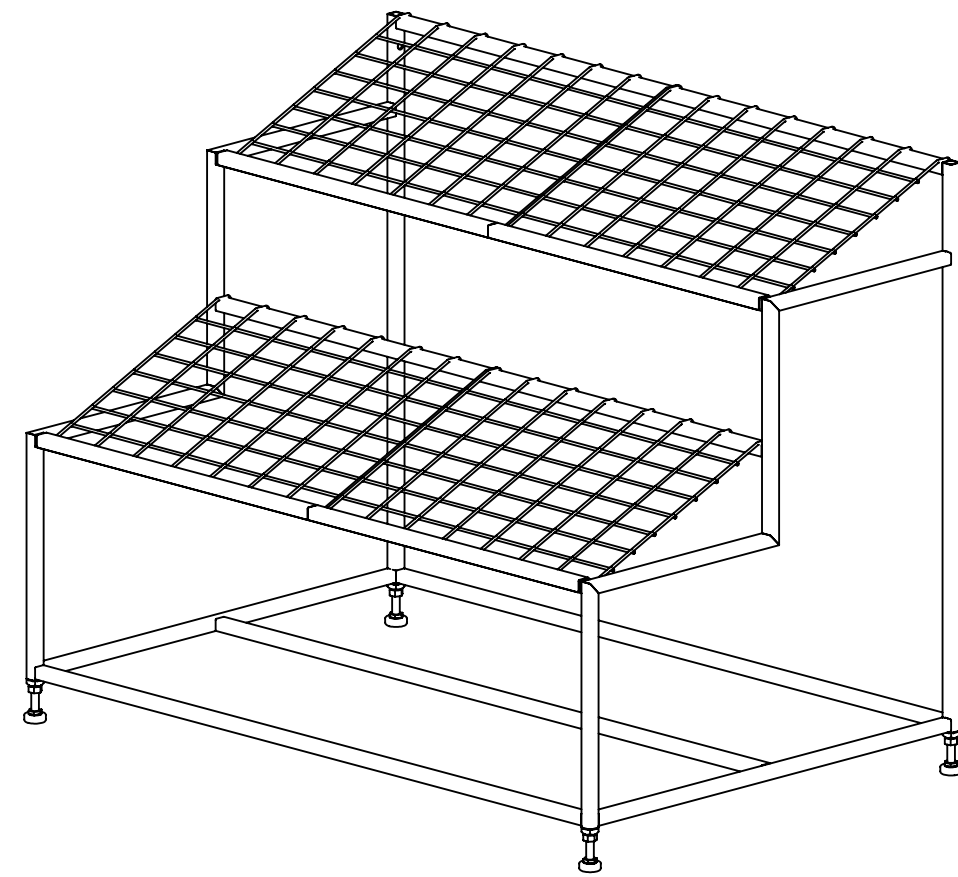

- 1 Framework Stairs — 1
- 9 Insert adjustable — 4
- 17 Inclined wire shelf — 4

EXTRA

More storage space
expand the capacity of
sales area

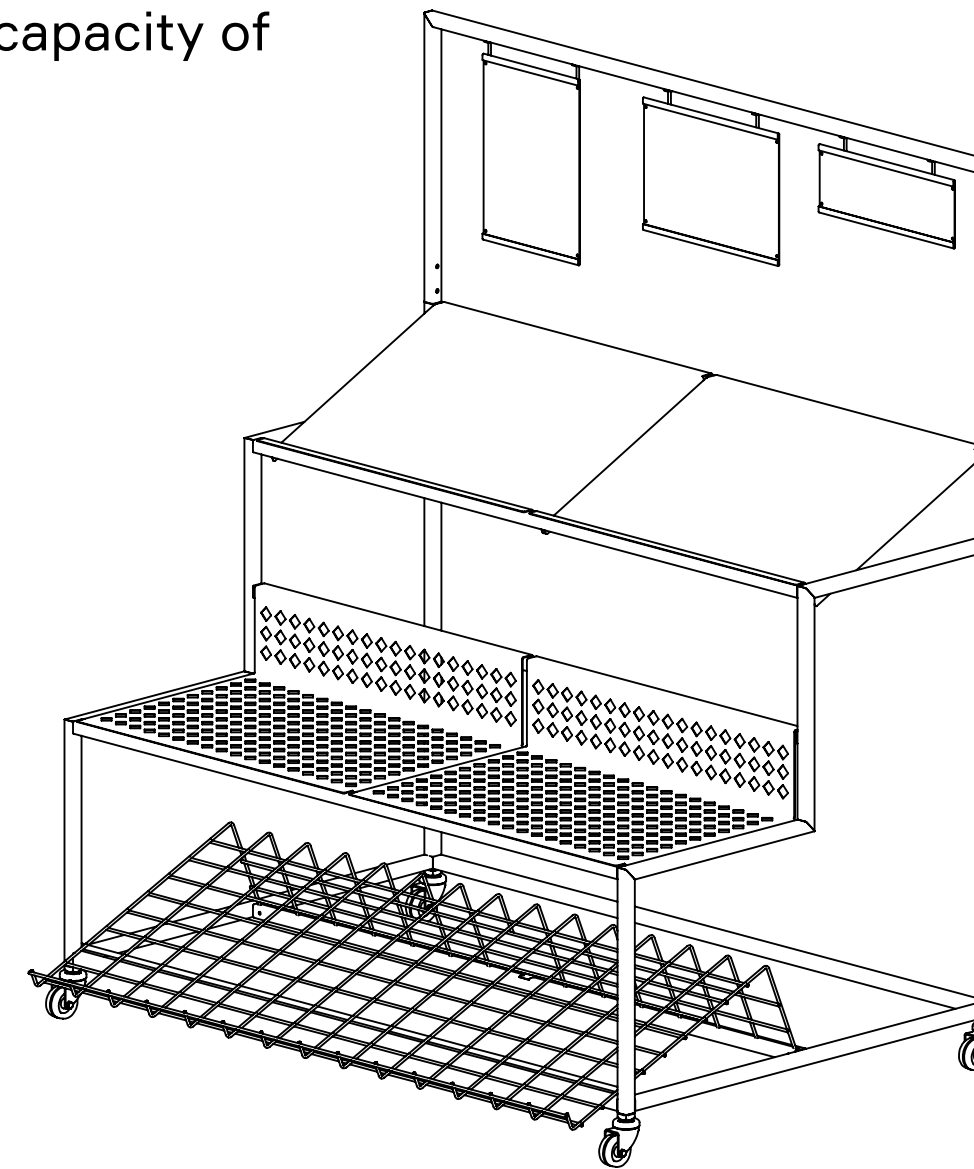

- 1 Framework Stairs — 1
- 10 Wheel with stopper — 4
- 13 Straight perforated shelf — 2
- 15 Inclined sheet shelf — 2
- 19 Base Inclined wire shelf — 1
- 20 Superstructure Stairs — 1
- 23 Promo panel 300x108 mm — 1
- 24 Promo panel 300x213 mm — 1
- 25 Promo panel 213x300 mm — 1

ADVANCED

Cross-selling solutions
ensure more impulse
purchases

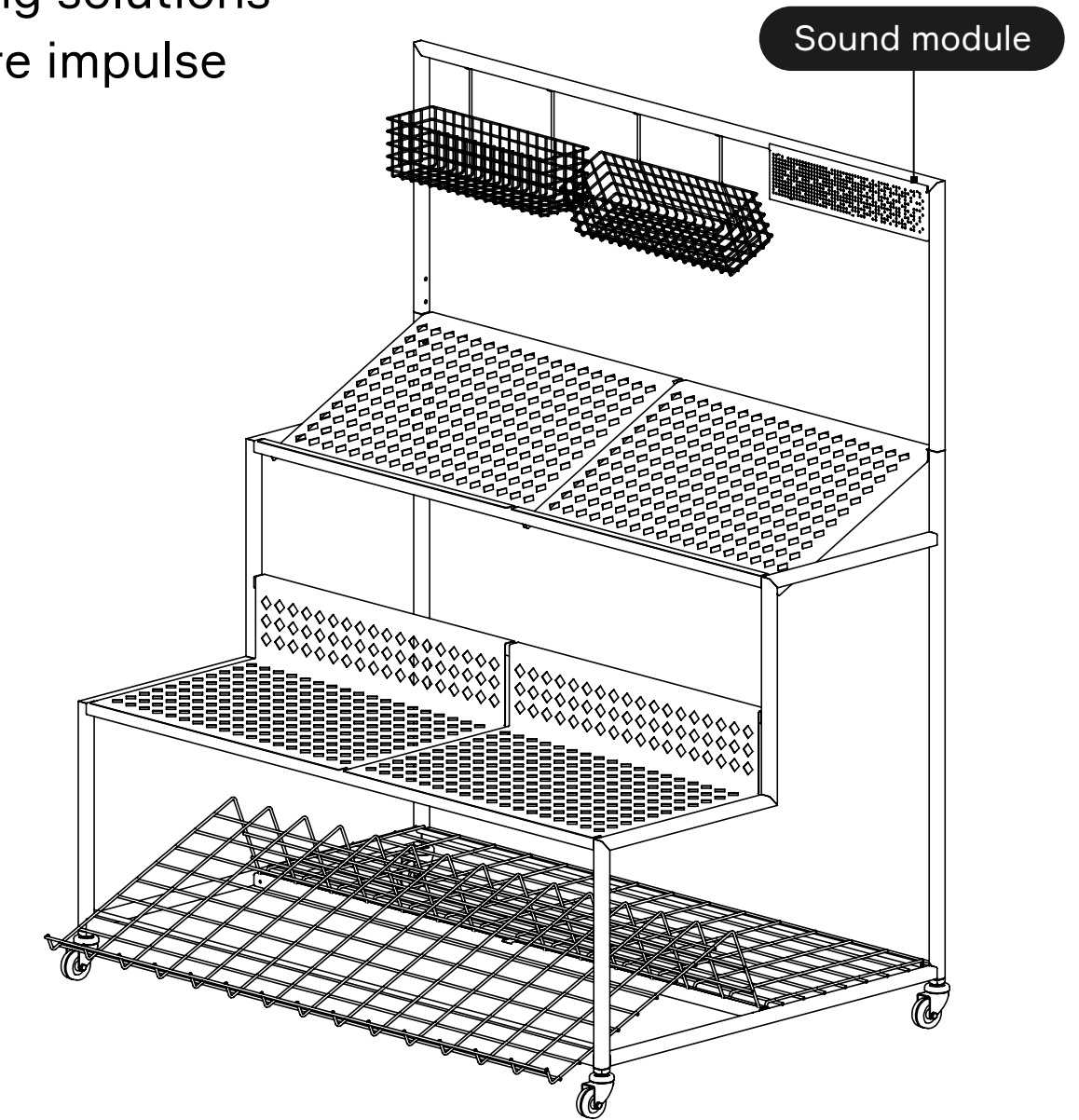

- 1 Framework Stairs — 1
- 10 Wheel with stopper — 4
- 11 Base straight wire shelf — 1
- 13 Straight perforated shelf — 2
- 16 Inclined perforated shelf — 2
- 19 Base Inclined wire shelf — 1
- 20 Superstructure Stairs — 1
- 26 Straight hinged basket — 1
- 27 Inclined hinged basket — 1
- 30 Sound module — 1

Click the number
to get details

Technical details

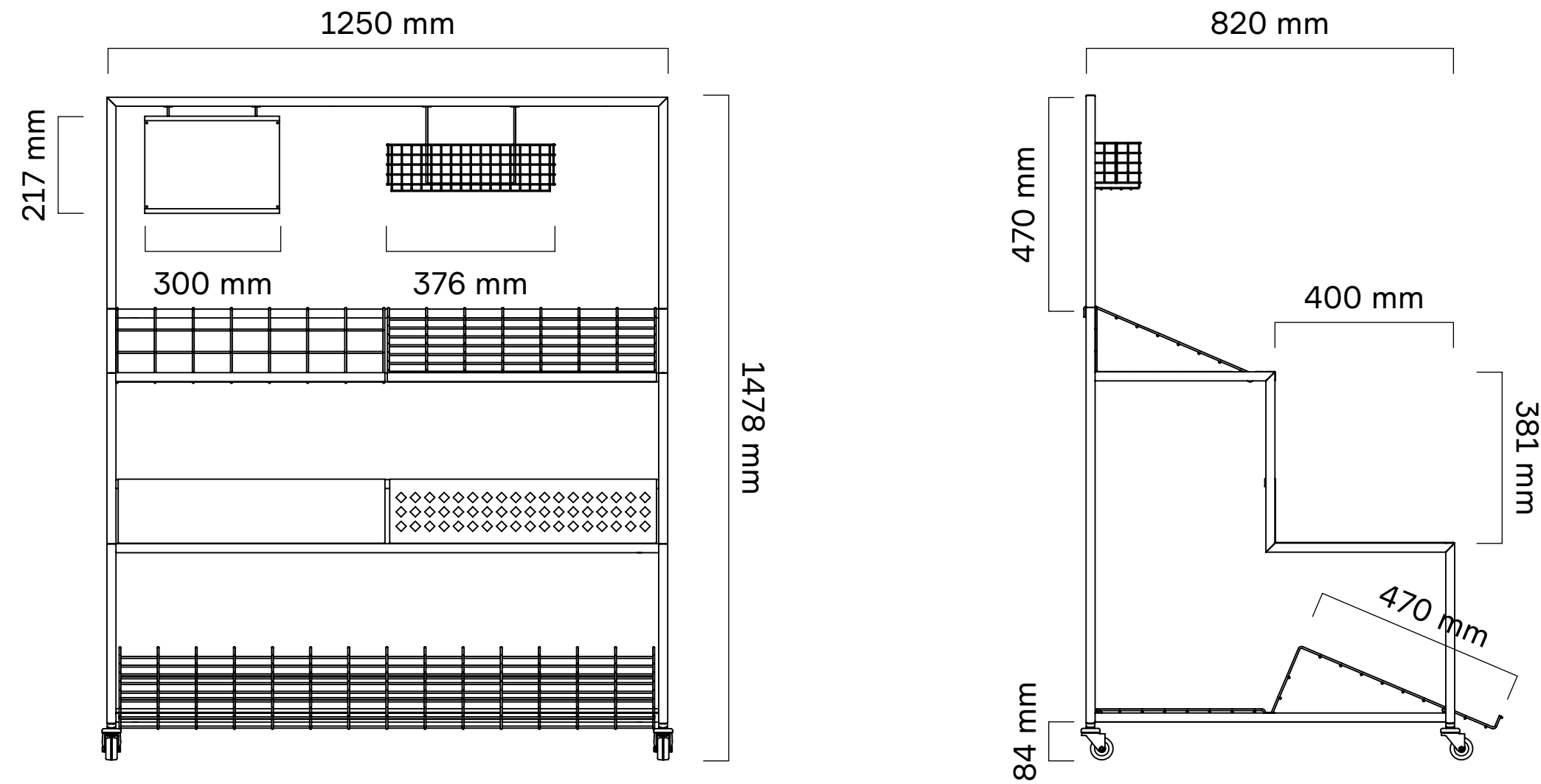

Structure of Stairs

Click the number to get details

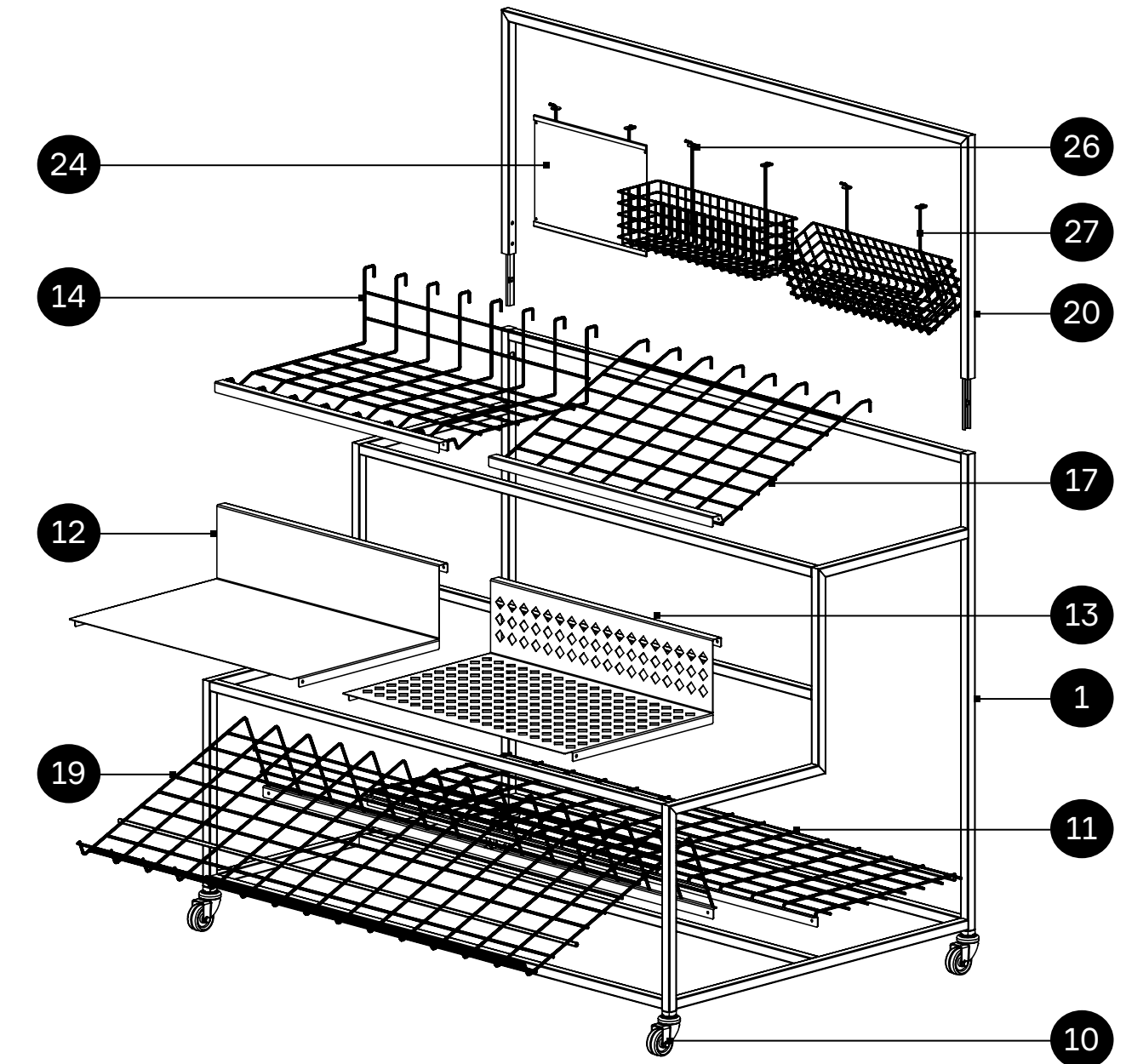

Folding framework

The only thing you need for bringing the framework together is cruciate screwdriver

Easy to assemble. Easy to disassemble. Easy to store

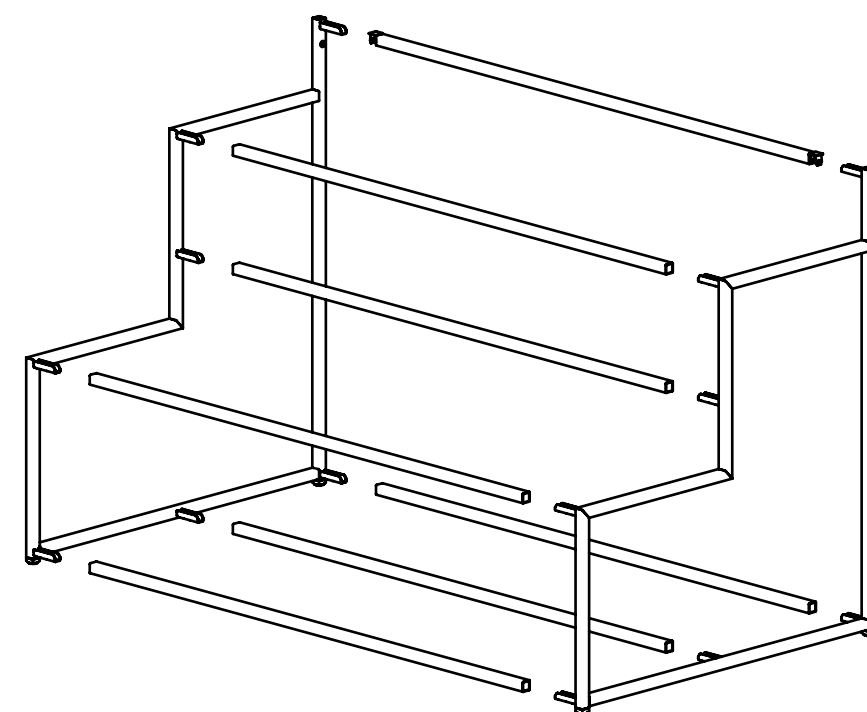

Load capacity

100 kg per level

400 kg per display

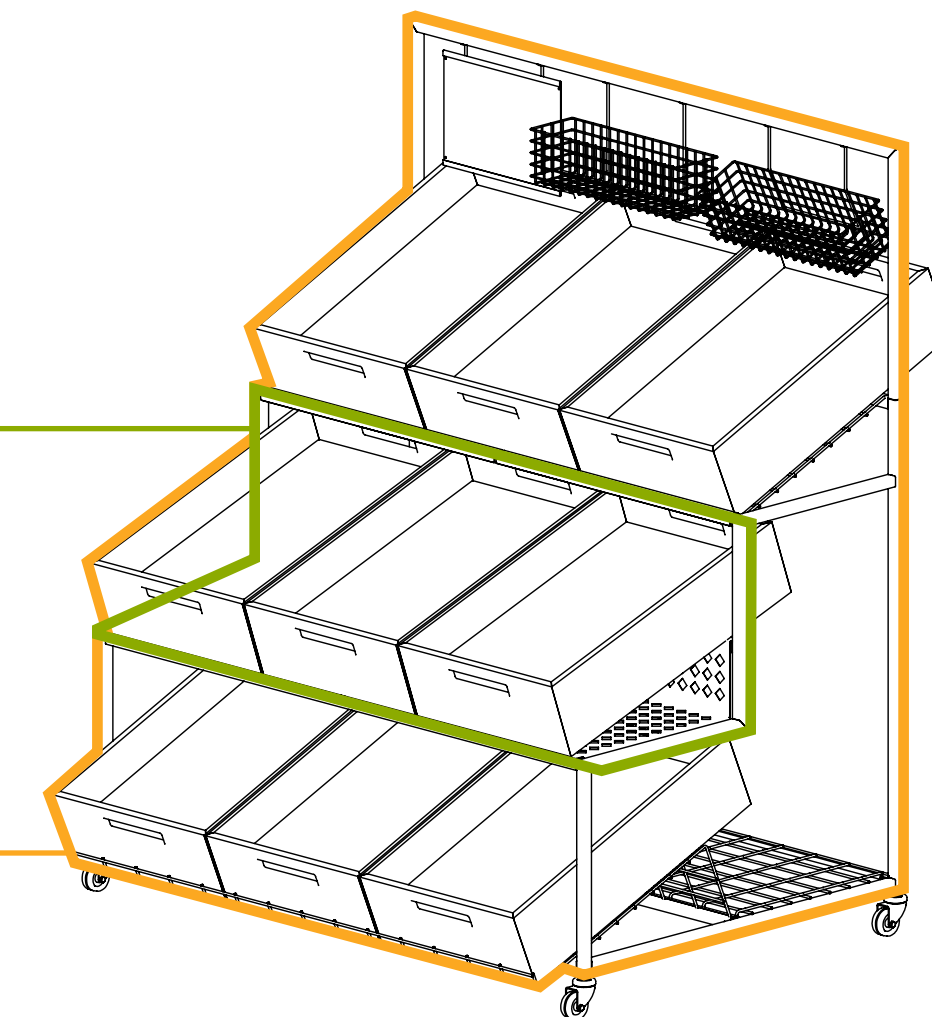

Storey

3-storey shelves display with sound module

Easy transform your F&V presentation zone even in limited spaces



Sound module



3-level exposition

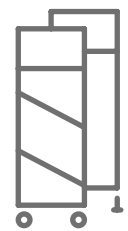

Mobile / stationary

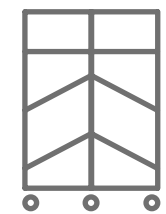

Wall / island unit



Folding frame base



Size

1250x420x1408

Materials

metal square pipe

metal sheet

wire

Customize your Storey

Examples of sets

BASIC

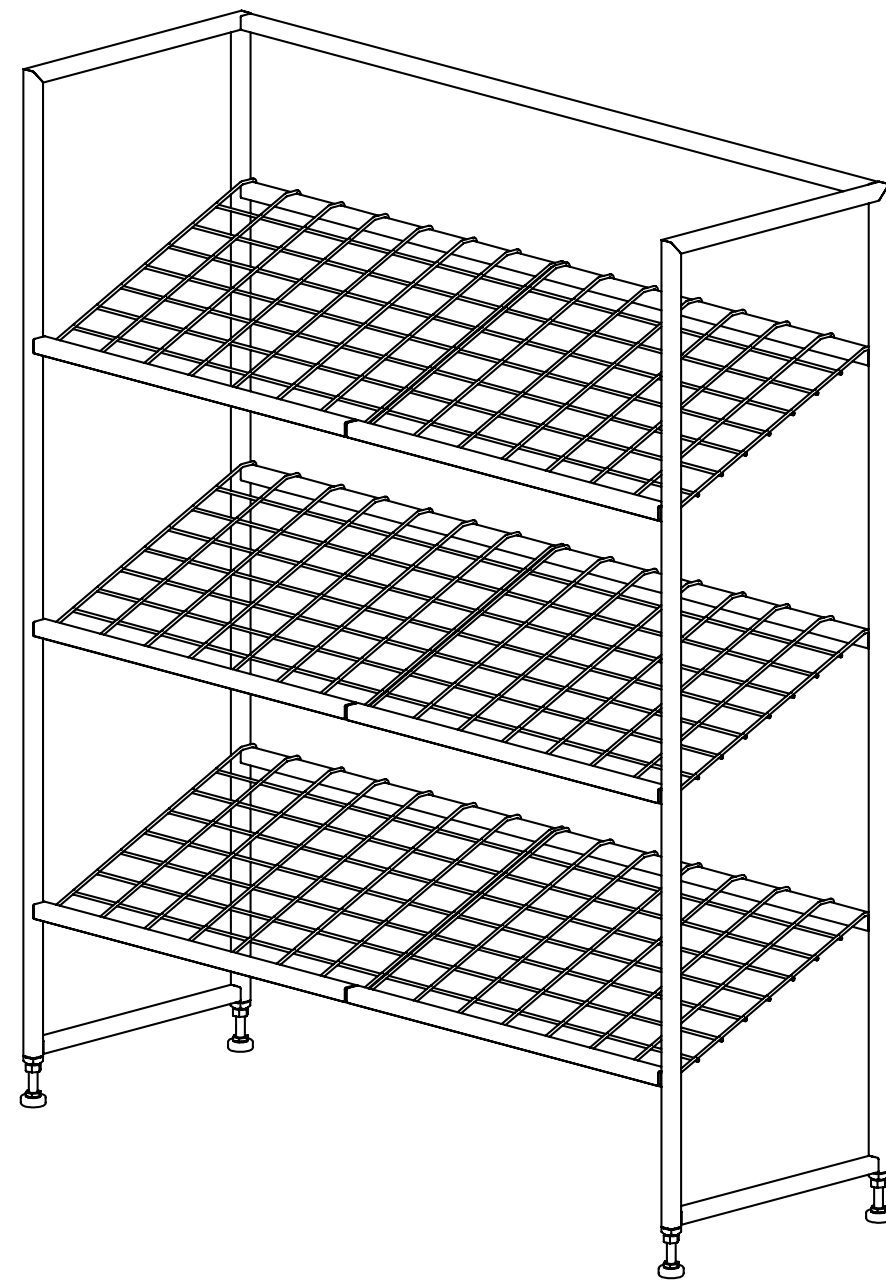

2 Framework Storey — 1

9 Insert adjustable — 4

17 Inclined wire shelf — 6

ADVANCED



2 Framework Storey — 1

10 Wheel with stopper — 4

12 Straight sheet shelf — 1

13 Straight perforated shelf — 1

14 Straight wire shelf — 1

15 Inclined sheet shelf — 1

16 Inclined perforated shelf — 1

17 Inclined wire shelf — 1

23 Promo panel 300x108 mm — 2

30 Sound module — 1

Click the number
to get details

Technical details

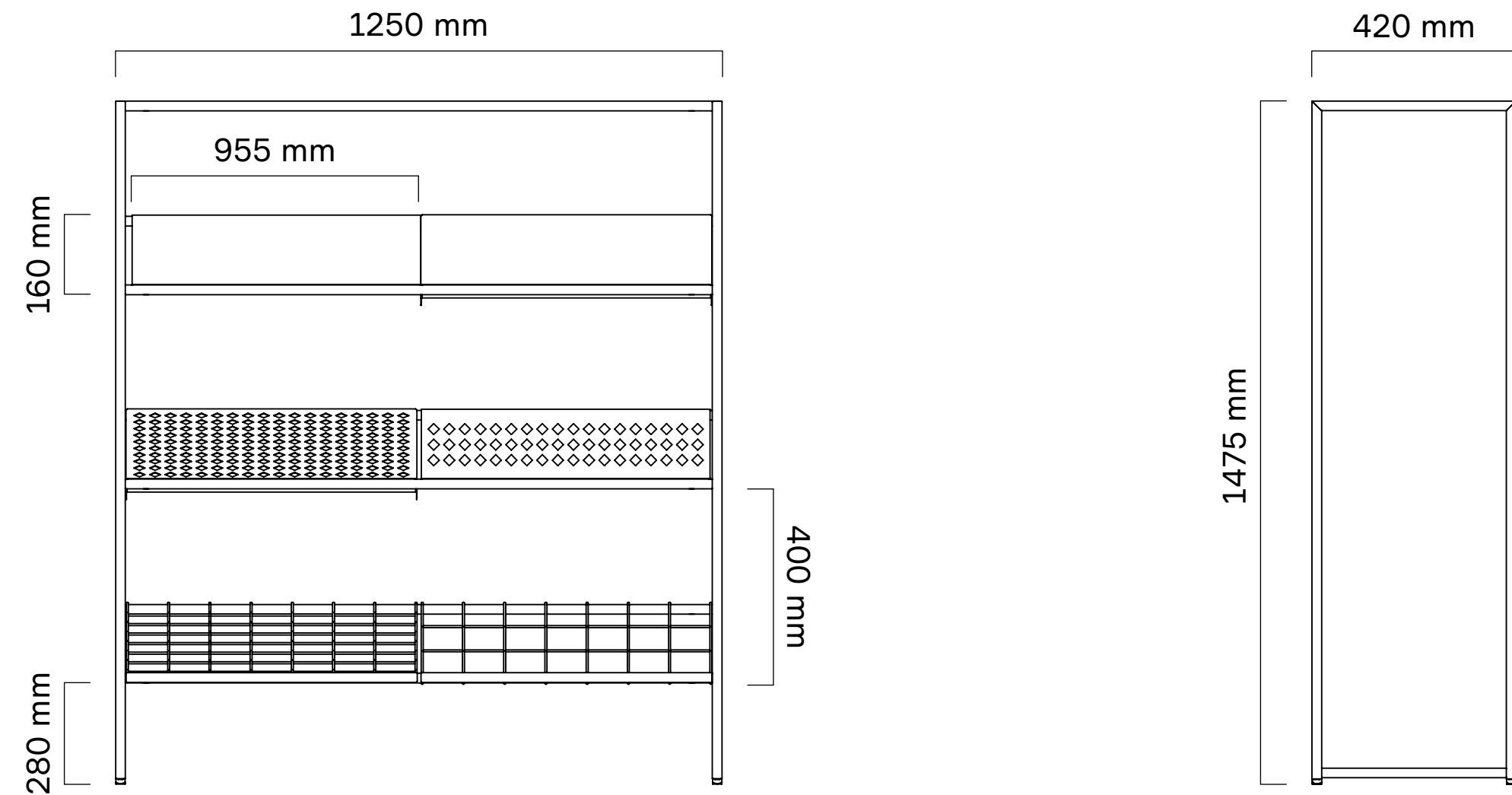

Structure of Storey

Click the number to get details

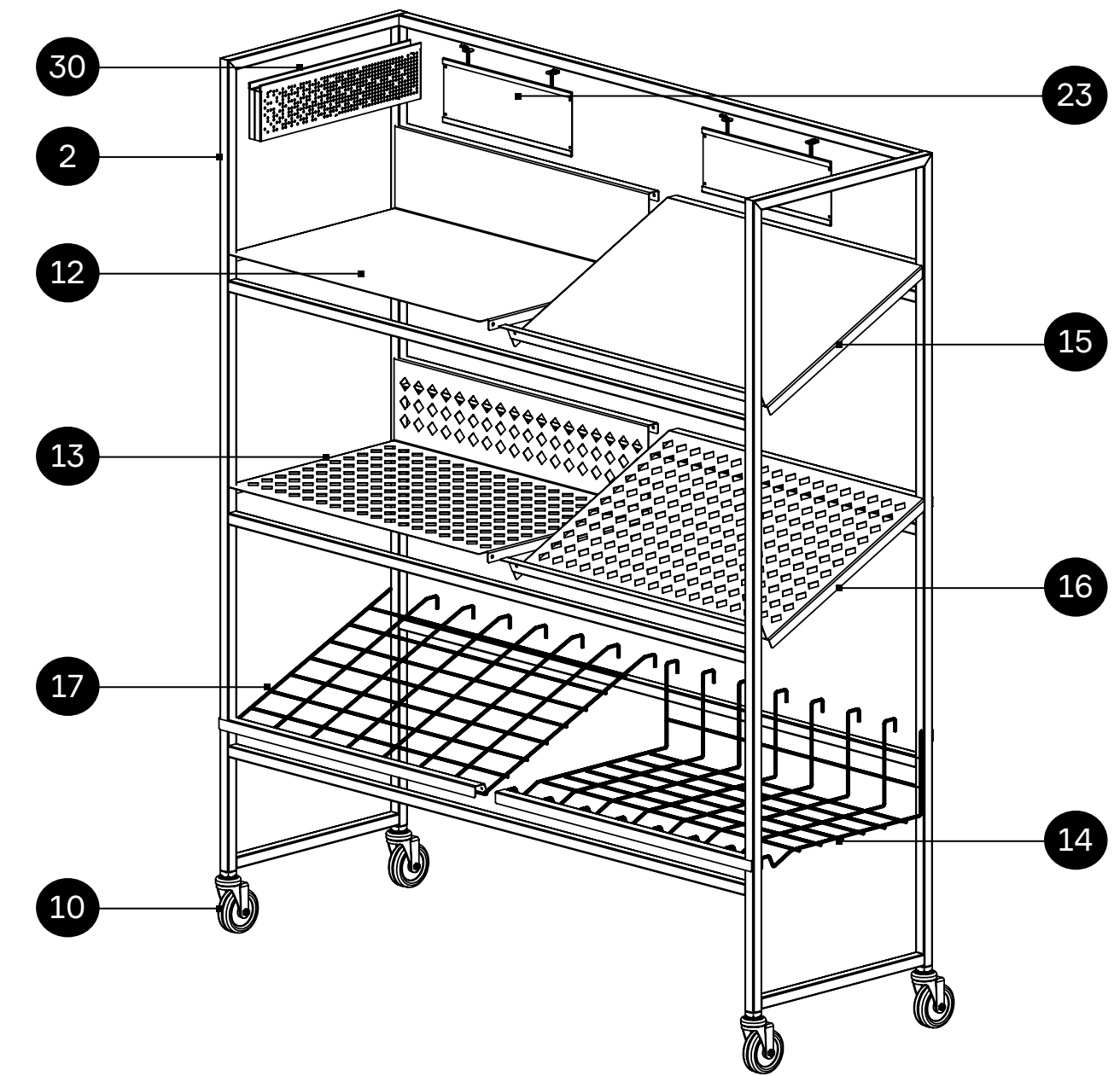

Folding framework

The only thing you need for bringing the framework together is cruciate screwdriver

Easy to assemble. Easy to disassemble. Easy to store

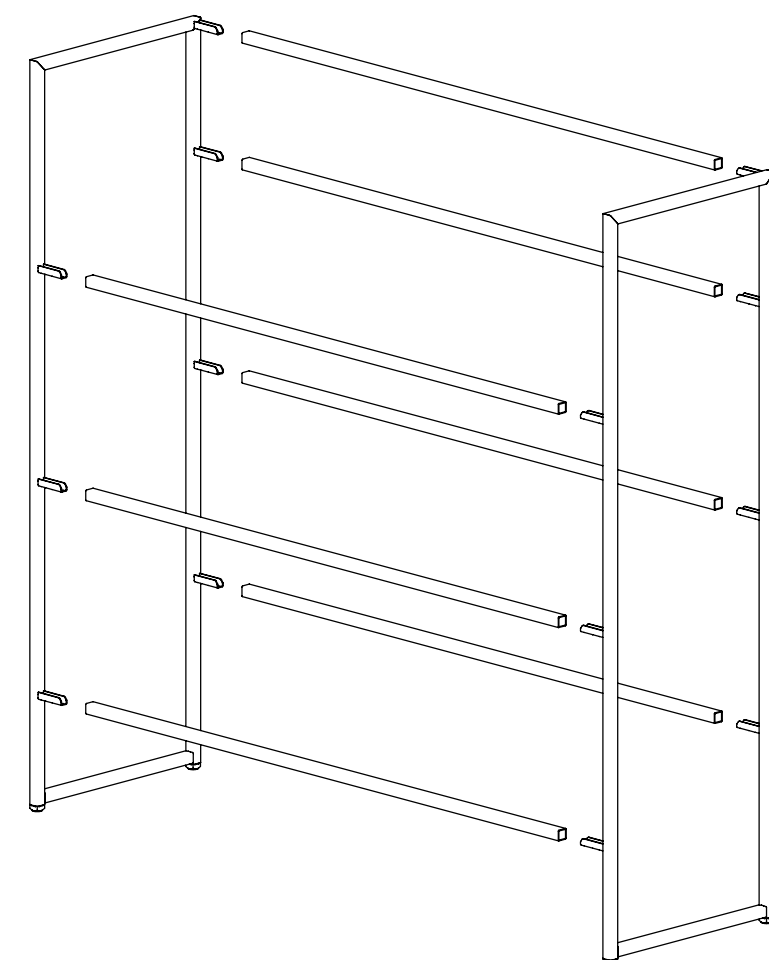

Load capacity

100 kg per level

300 kg per display

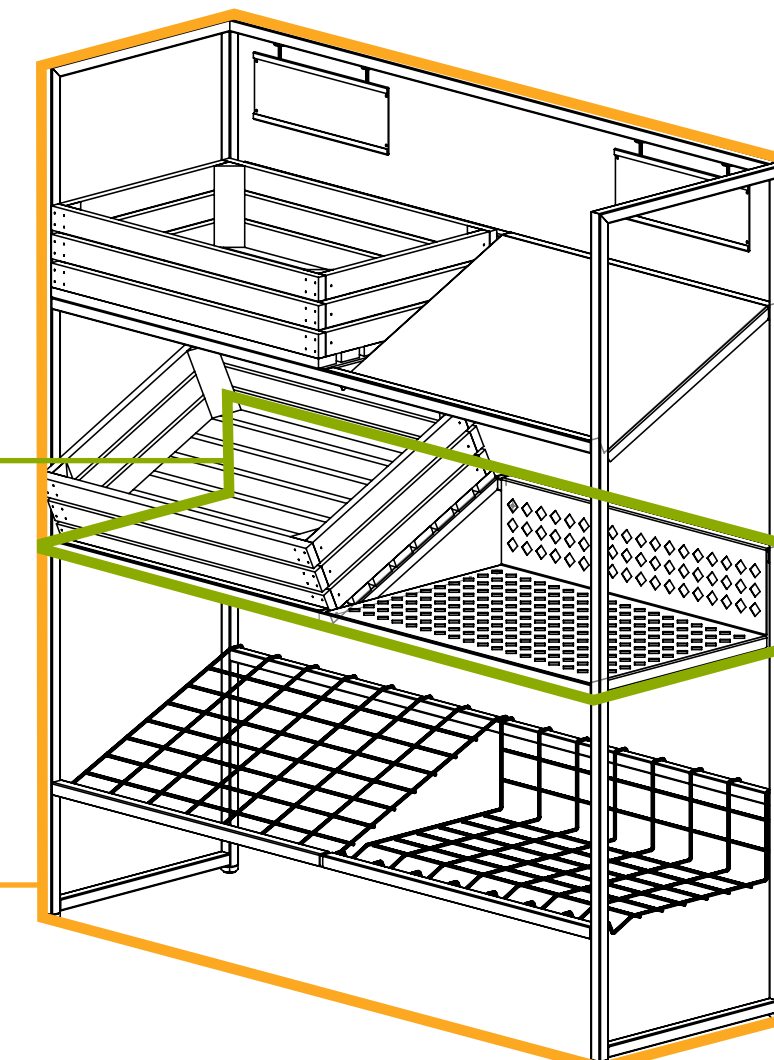

Plateau

Low easy-to-modify platform
with sound module

Provide your F&V presentation easily
with unique atmosphere of open
parks, gardens and markets

Size

1250x820x411

Materials

metal square pipe

metal sheet

wire

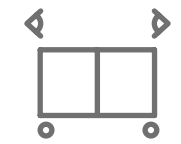

360°
presentation



2-level
exposition



Mobile /
stationary



Product presen-
tation / open
sitting place



Reinforces
straight metal
sheet shelf



Inclined /
straight
shelves

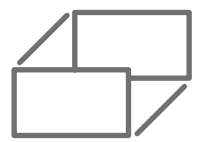

Folding
frame base



Pool of accessories
for adjustable
construction



Sound
module



Customize your Plateau

Examples of sets

BASIC

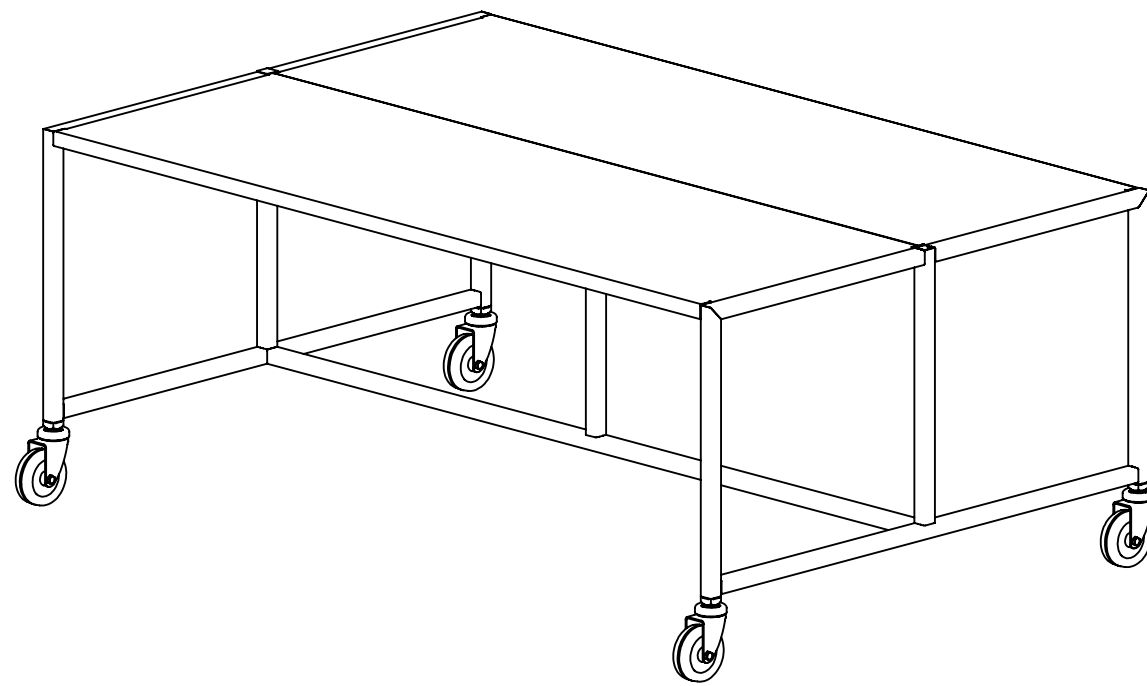

- 3 Framework Plateau — 1
- 10 Wheel with stopper — 4
- 28 Reinforced shelf — 2

EXTRA

More capacity of sales area

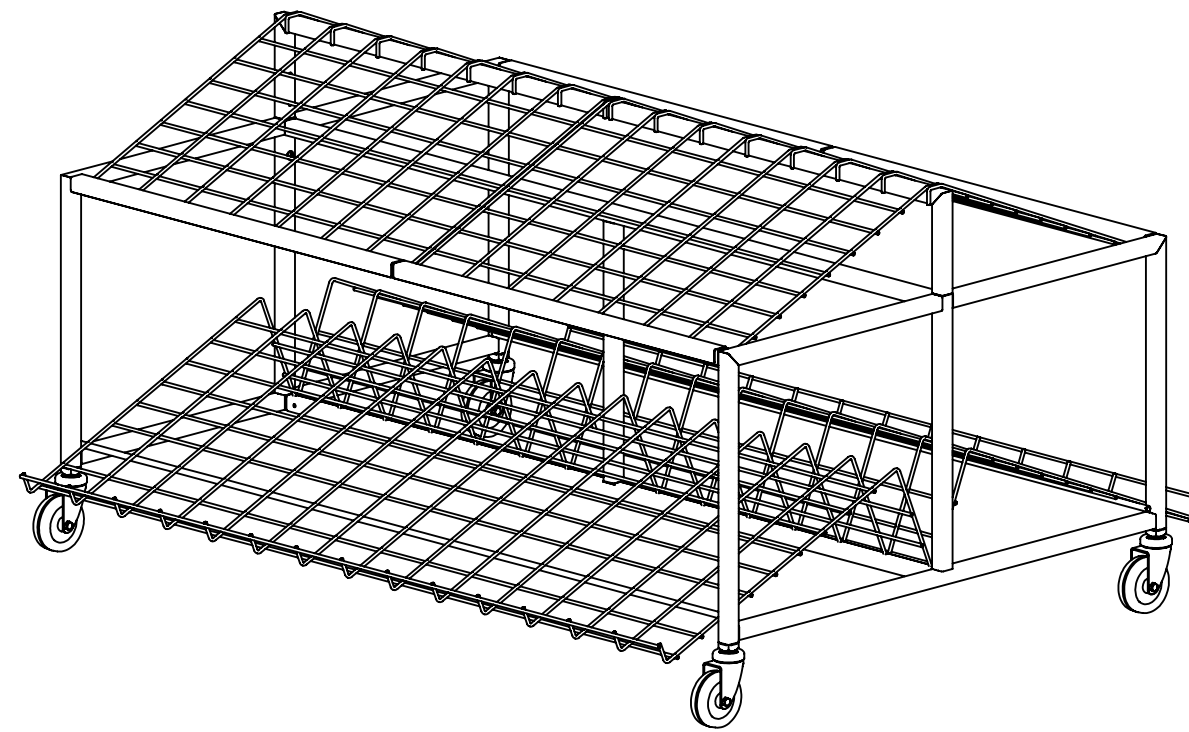

- 3 Framework Plateau — 1
- 10 Wheel with stopper — 4
- 17 Inclined wire shelf — 4
- 19 Base Inclined wire shelf — 2
- 21 Superstructure Plateau — 1

ADVANCED

Plenty of solutions for the product presentation and more storage space

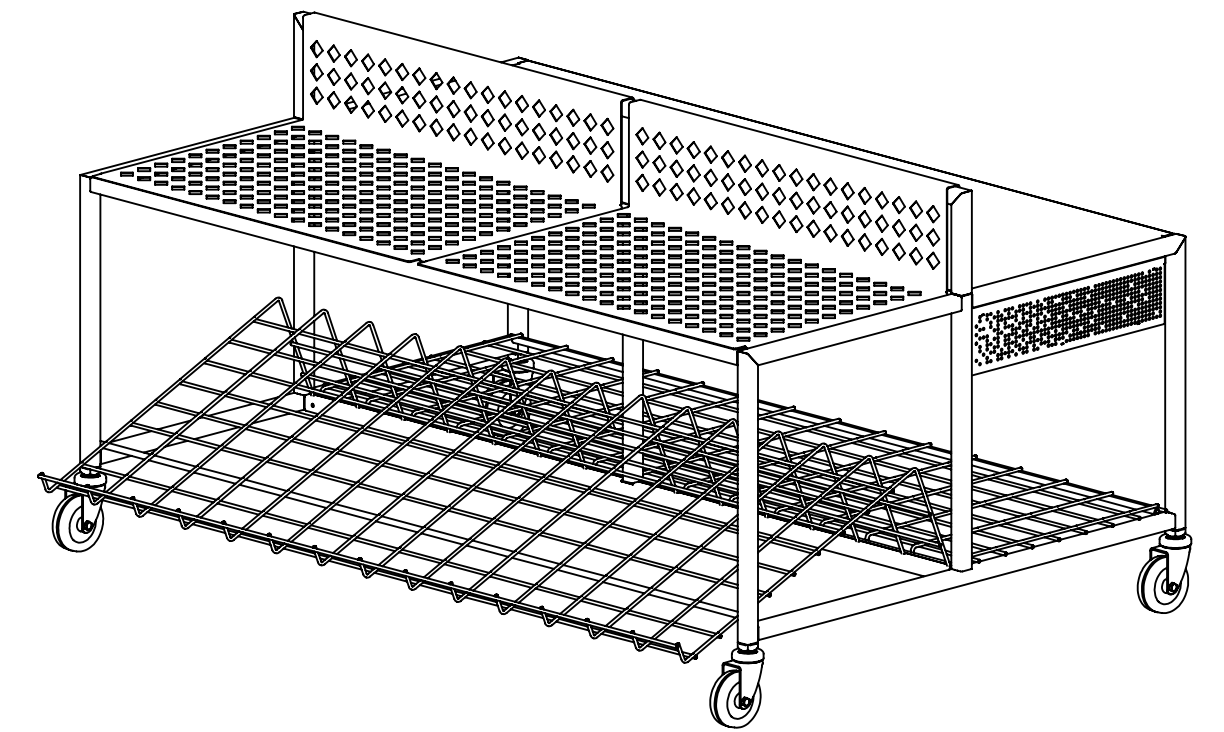

- 3 Framework Plateau — 1
- 10 Wheel with stopper — 4
- 13 Straight perforated shelf — 2
- 18 Base straight wire shelf — 1
- 19 Base Inclined wire shelf — 1
- 21 Superstructure Plateau — 1
- 28 Reinforced shelf — 1
- 30 Sound module — 1

Click the number
to get details

Technical details

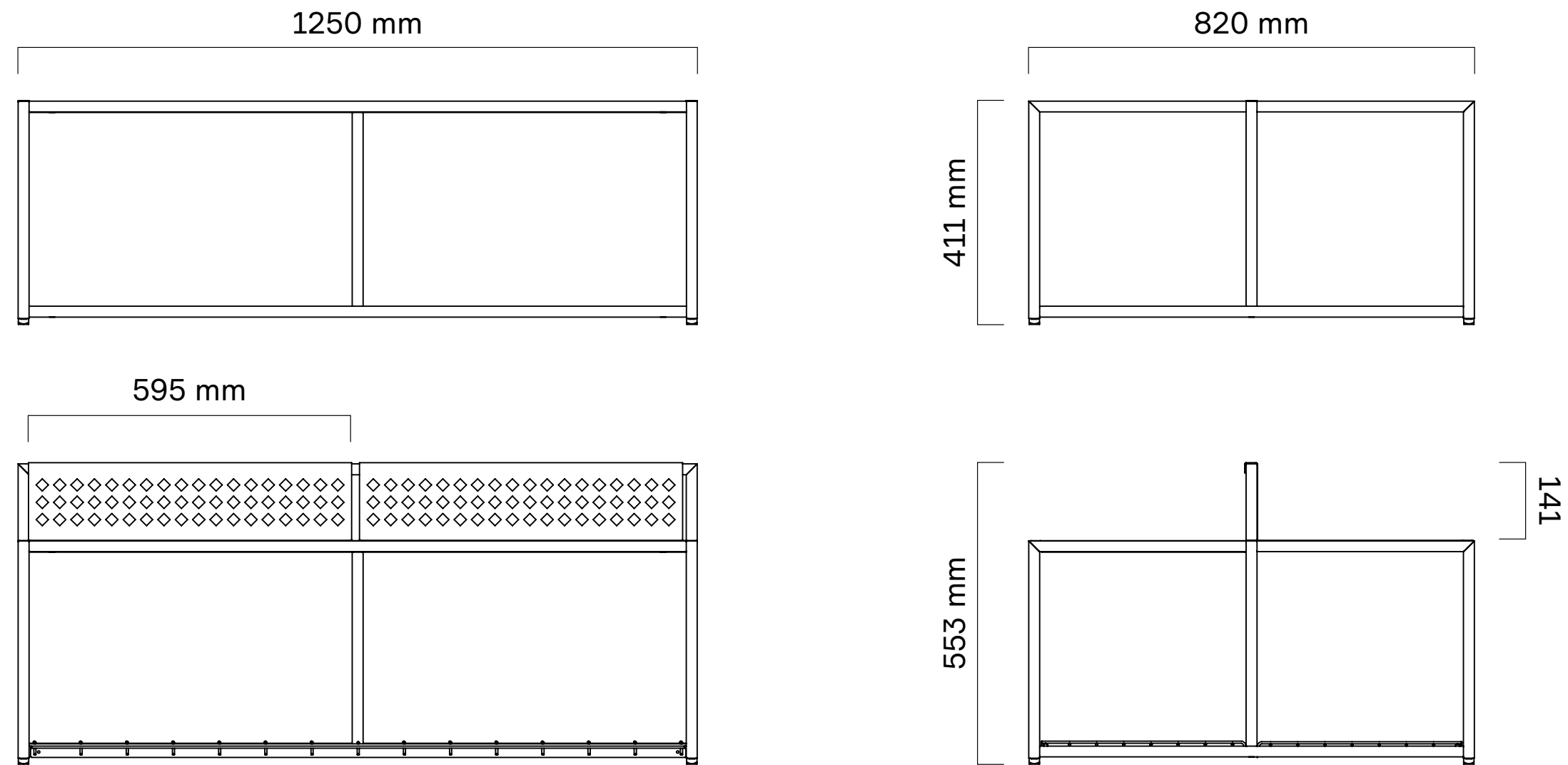

Structure of Plateau

Click the number to get details

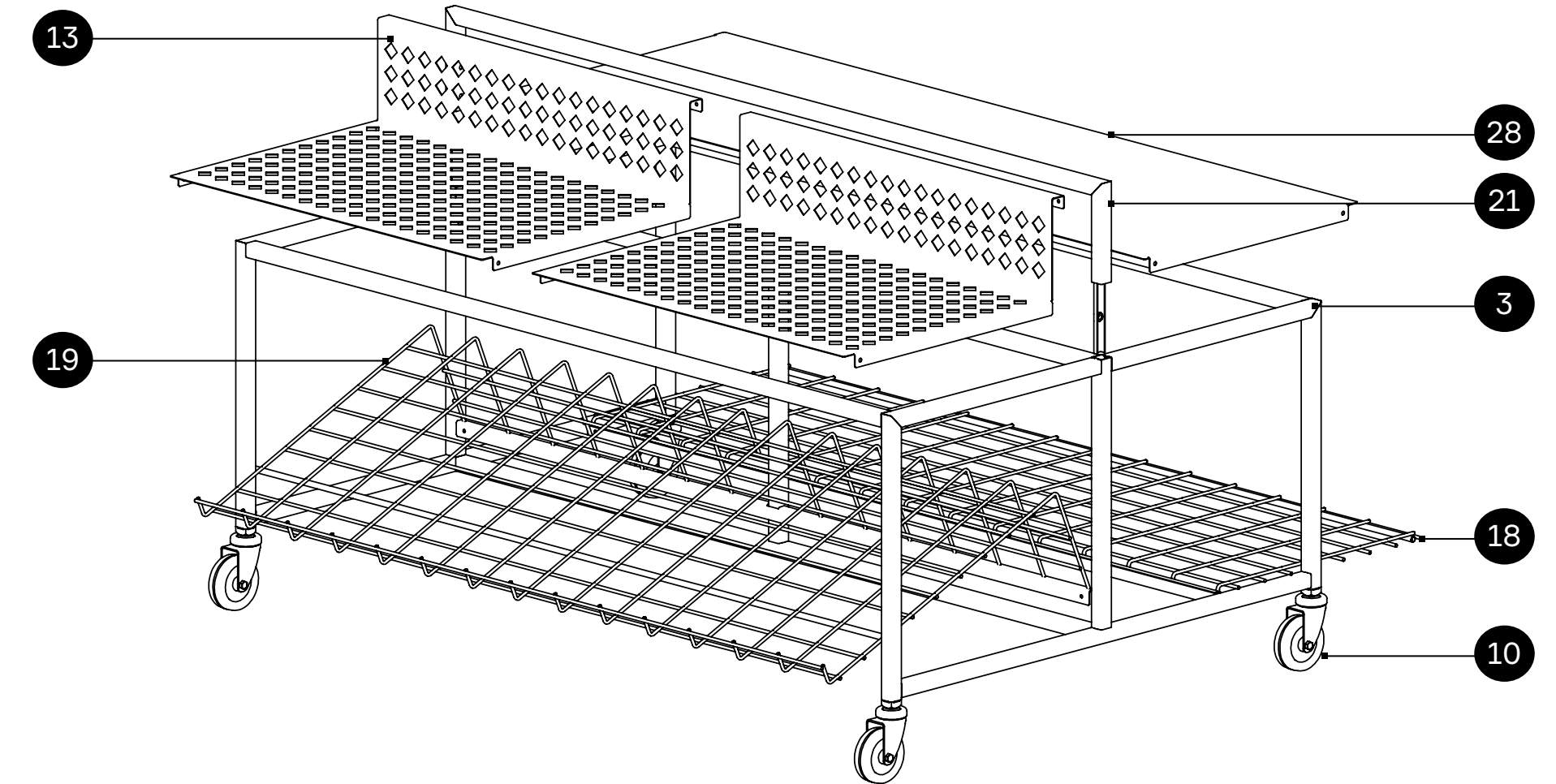

Folding frame base

The only thing you need for bringing the framework together is cruciate screwdriver

Easy to assemble. Easy to disassemble. Easy to store

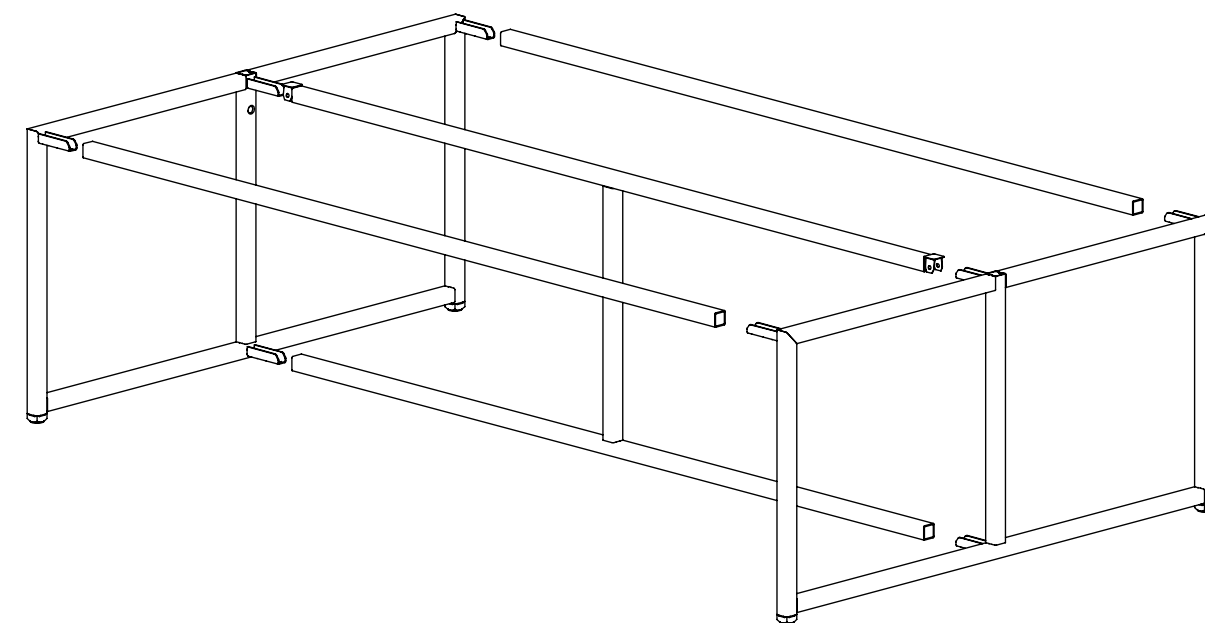

Load capacity

50 kg per shelf

200 kg per reinforced shelf

400 kg per display

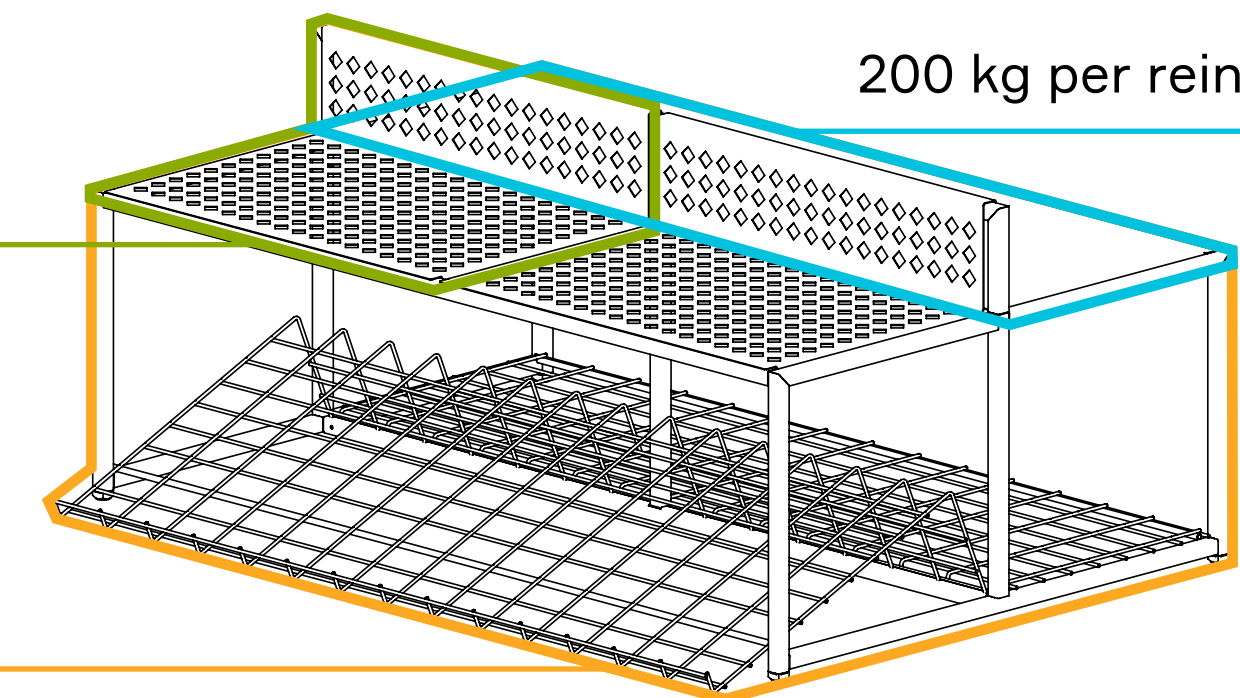

Greora's well-designed details

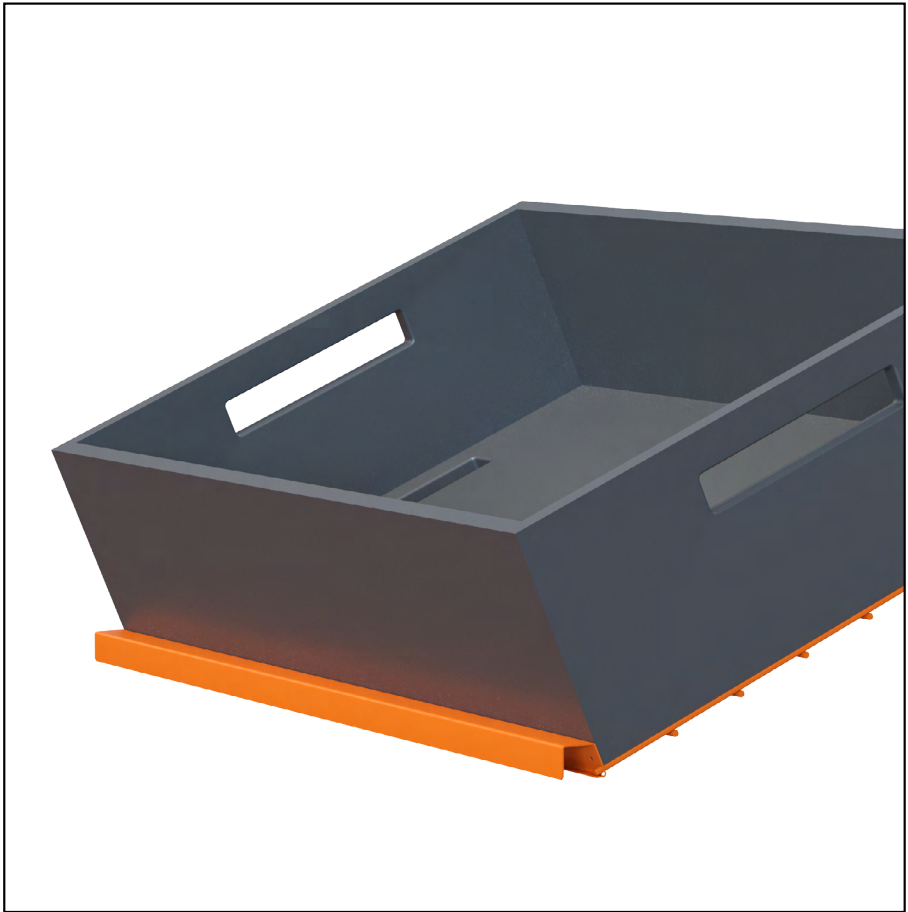

Front barriers on inclined shelves protects from sliding off the boxes

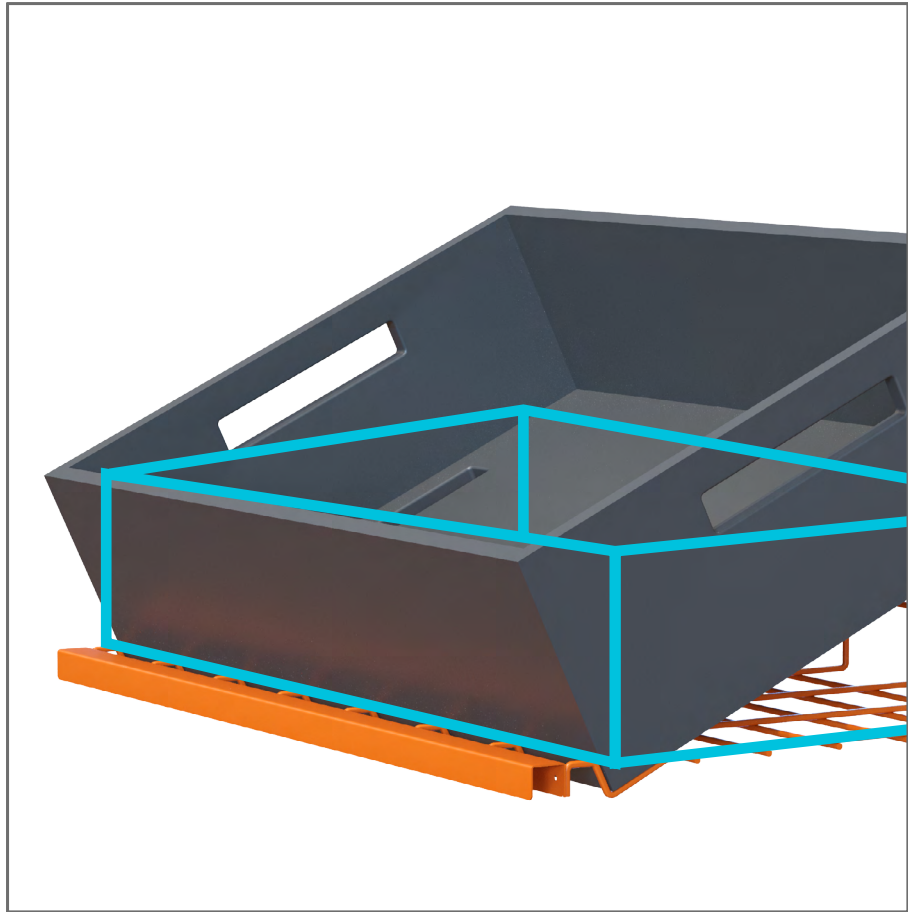

The tilt of the boxes on a straight shelf can be changed in one move



Mobile

Swivel wheels provide a great maneuverability



Stationary

Adjustable legs inserts provide stability even on uneven surfaces

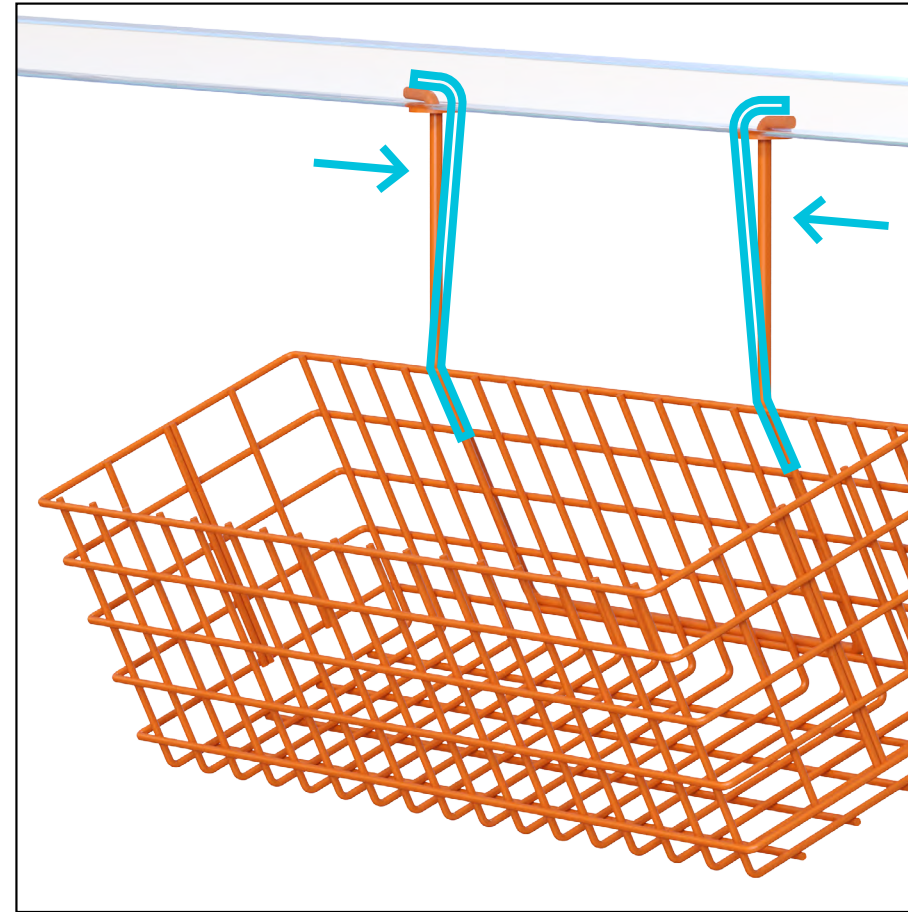

Easy installation of baskets

Trapez

Layered and easy-to-modify
expositions tables

Dynamically transform your F&V
exposition tables into furniture for
interactive events

Sizes

Trapez L
1752x1347x708

Trapez S
950x750x447

Materials

metal square pipe

metal sheet

stainless steel

Trapez L

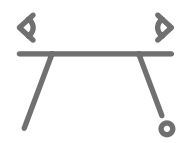

360° F&V
presentation

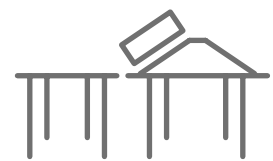

Countertop adapter
for inclined exposition

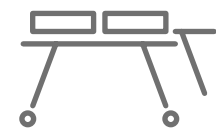

Mobile /
stationary



Easy
cleaning

Trapez S

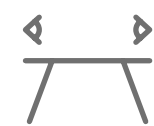

360° F&V
presentation



Narrow promo
furniture



Stationary



Easy
cleaning



Technical details

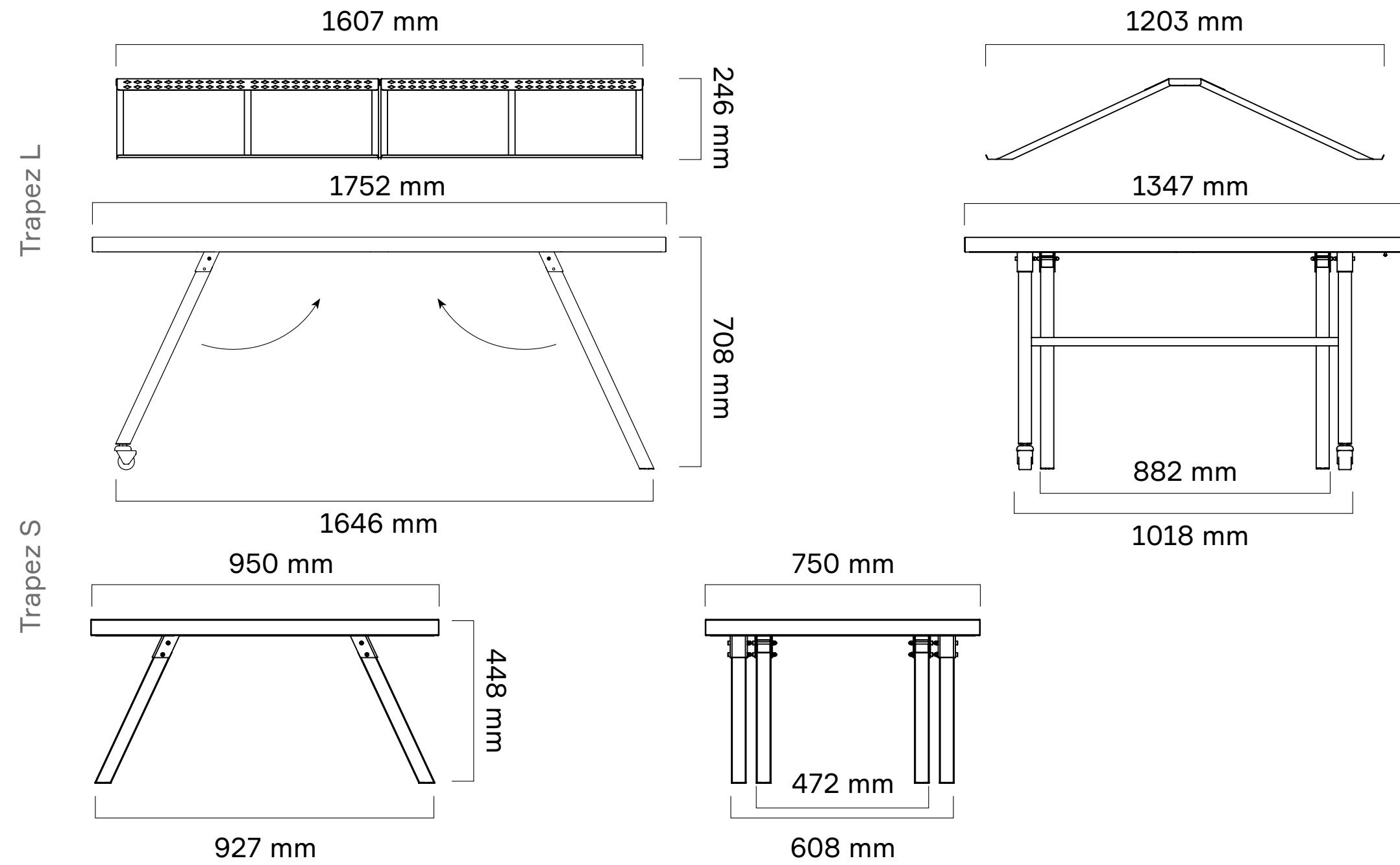

Structure of Trapez L

Click the number to get details

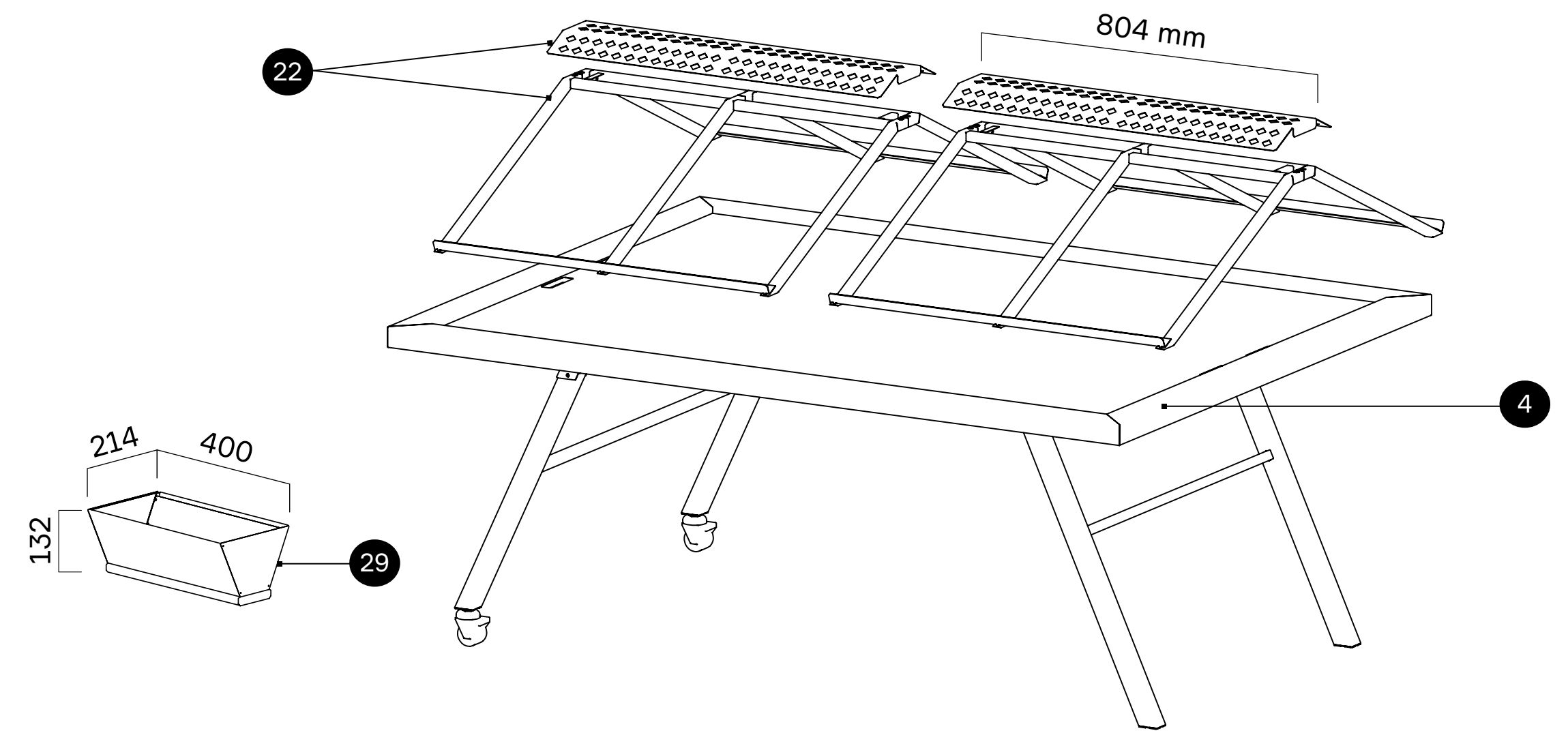

The legs of the table easily folded for transportation or storage

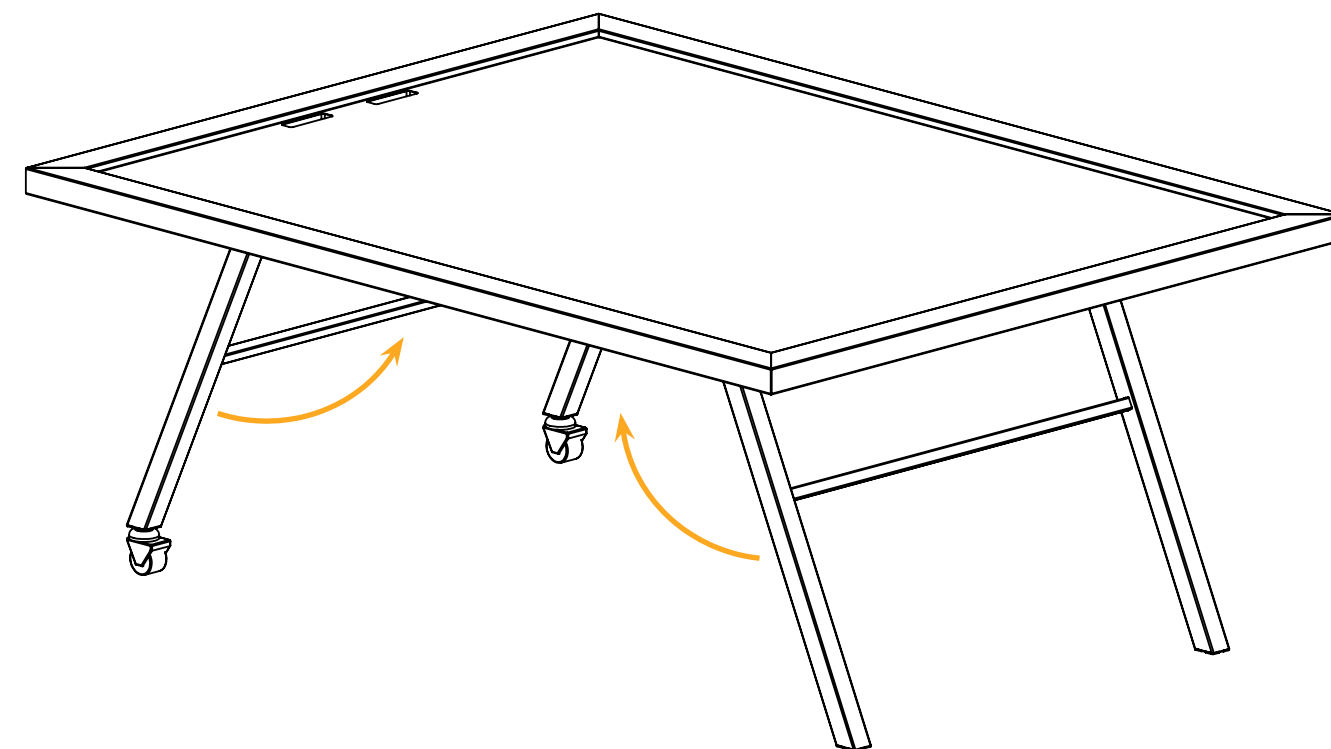

Load capacity

200 kg per superstructure

400 kg per table

200 kg per table

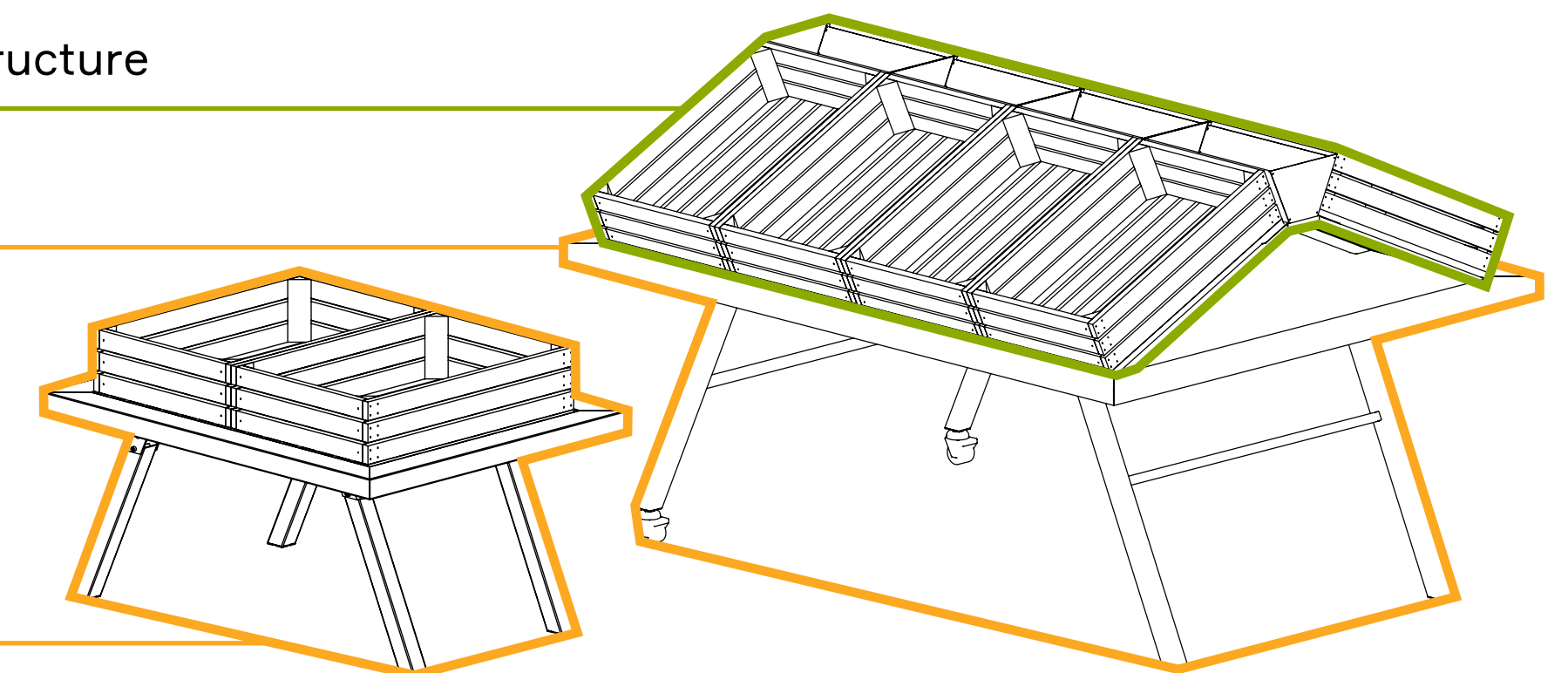

Box

Low bargain double assignment baskets

Modify atmosphere of your F&V zone
— extend assignment of Box from bargain to the planter

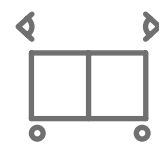

360°
presentation



Wire / acrylic /
plywood



Mobile /
stationary



Window basket /
Planter



Custom branding
as an option

Size
820x625x500
Materials
metal square pipe
wire
acrylic
plywood



Technical details

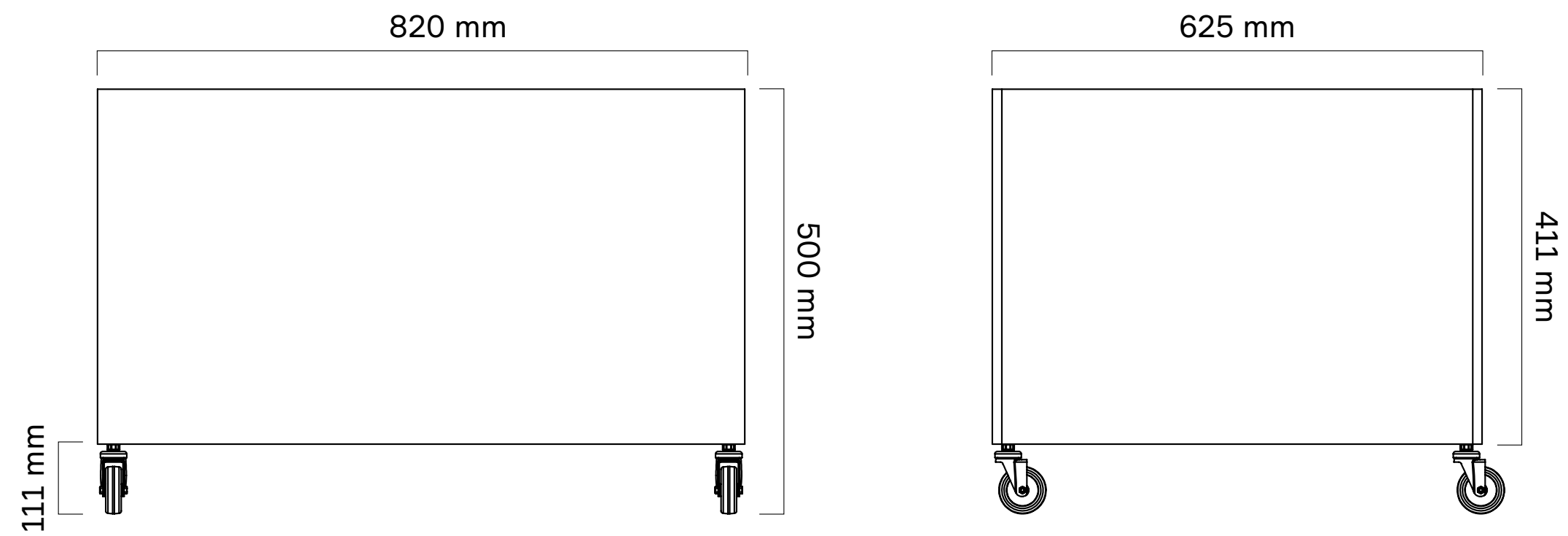

Load capacity

250 kg per Box

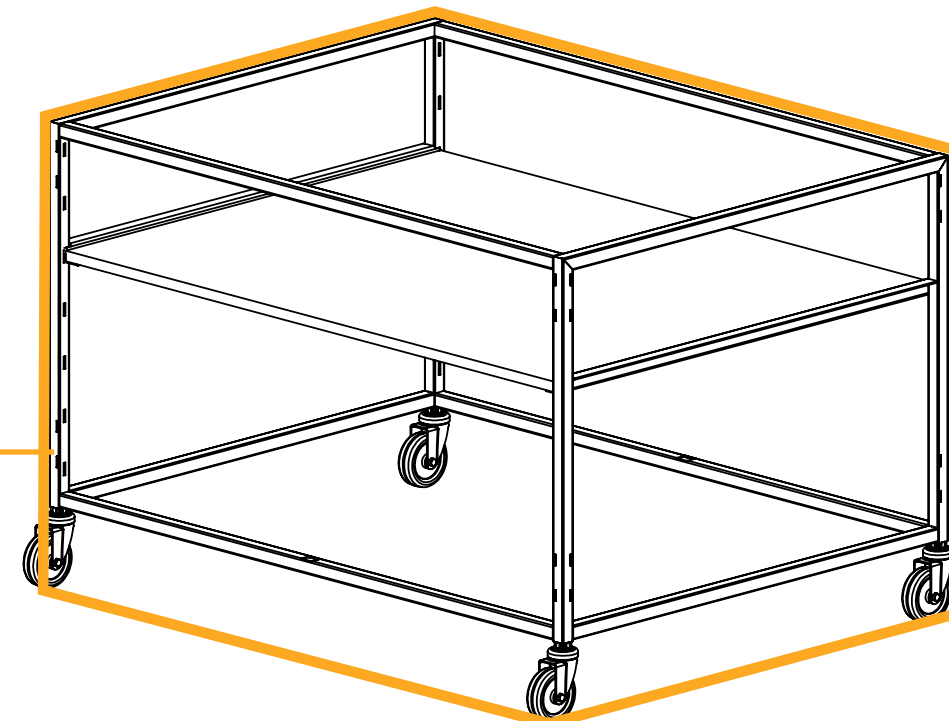

Structure of Box

The only thing you need for bringing the Box together is a cruciate screwdriver

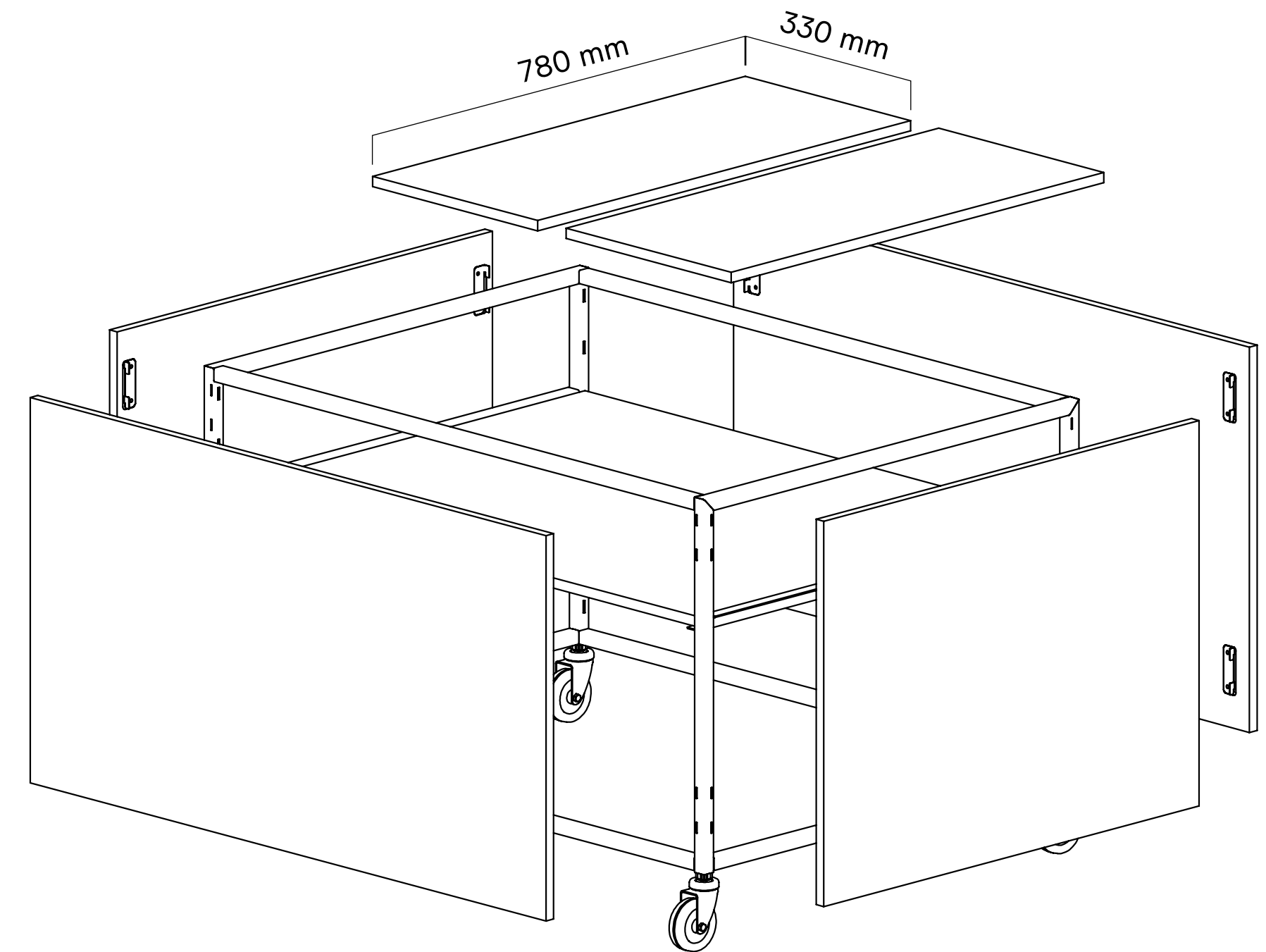

Sound Module

Solution concept

Enhance customers' shopping activity

Guide attention, entertain, educate and inspire your shoppers, express your brand

From soft nature sounds and fair atmosphere as a background to advertising messages

- > Wireless connection
- > Pop-up solution
- > Remote control as an option
- > Simple fixation with strong magnets

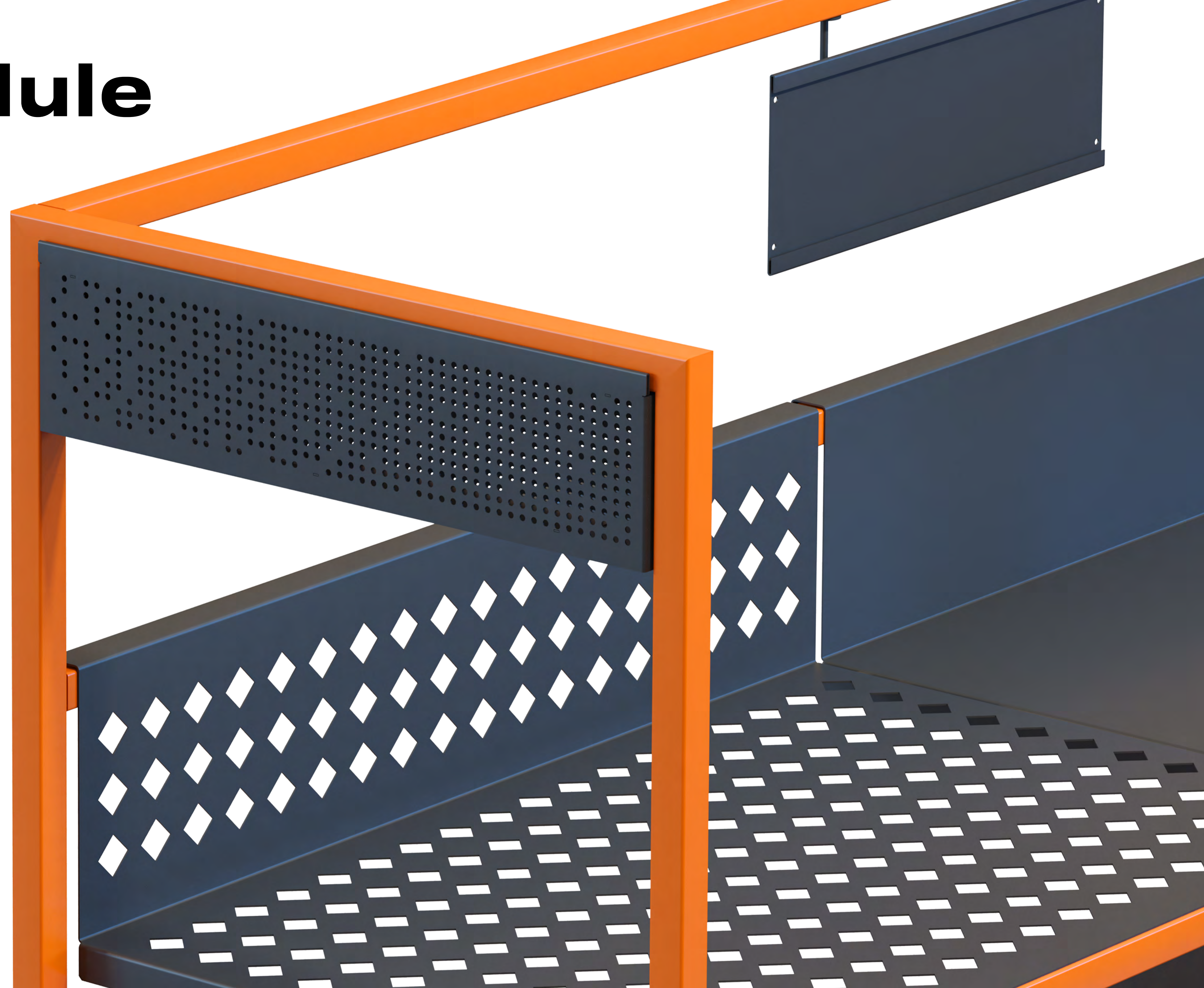

GrowerG

Solution concept

Indoor year-round growing unit
for your #newretail landscape

Welcome to the controlled
environmental agriculture world



Types of shelves

Stairs / Storey / Plateau

Straight shelves

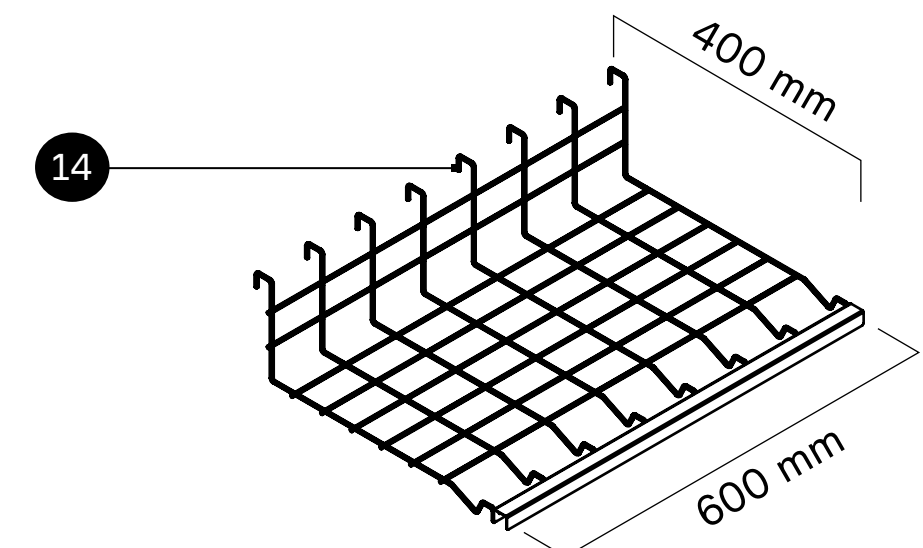
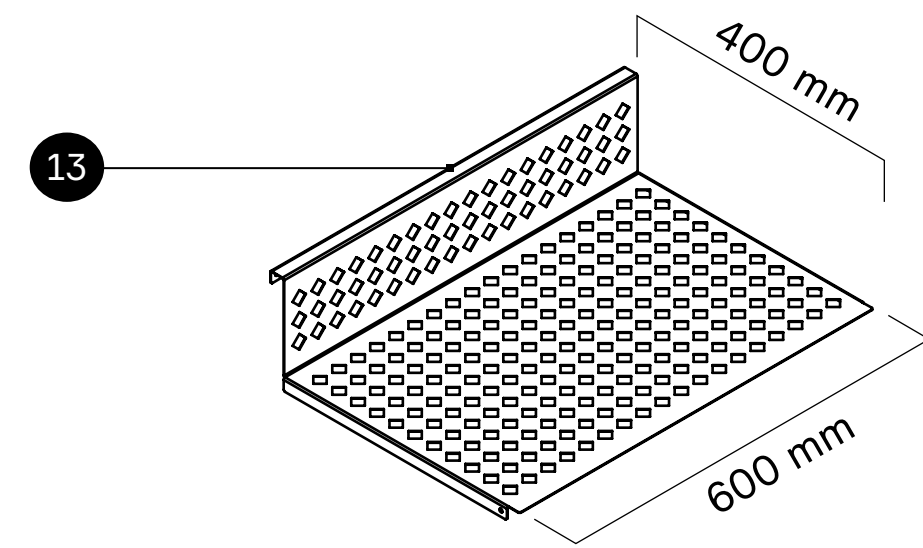
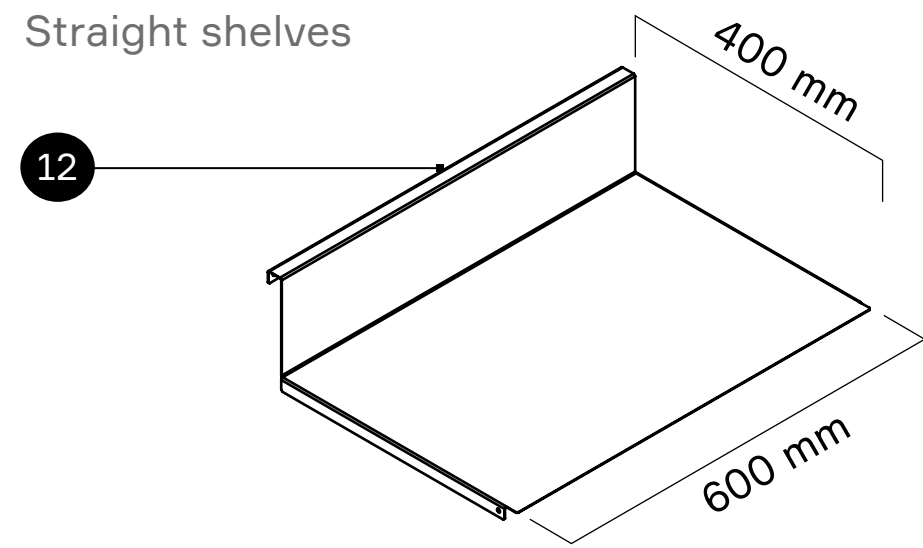

Inclined shelves

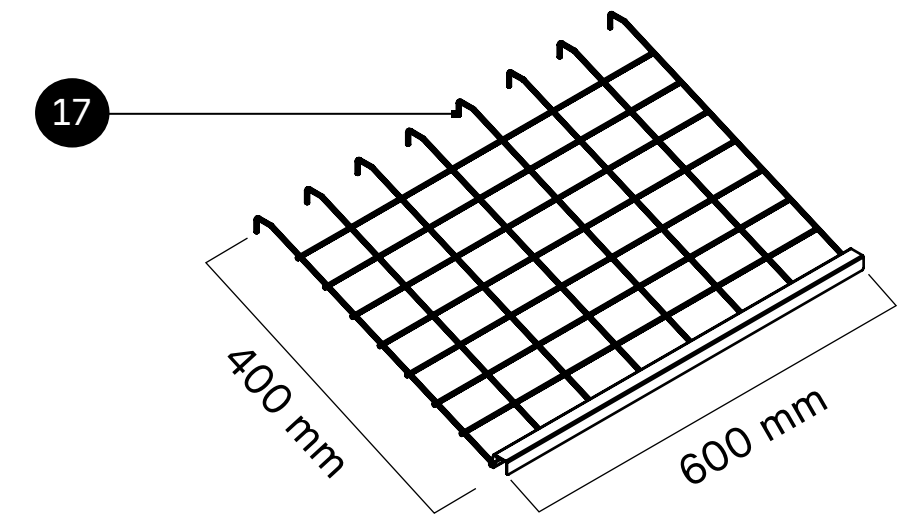
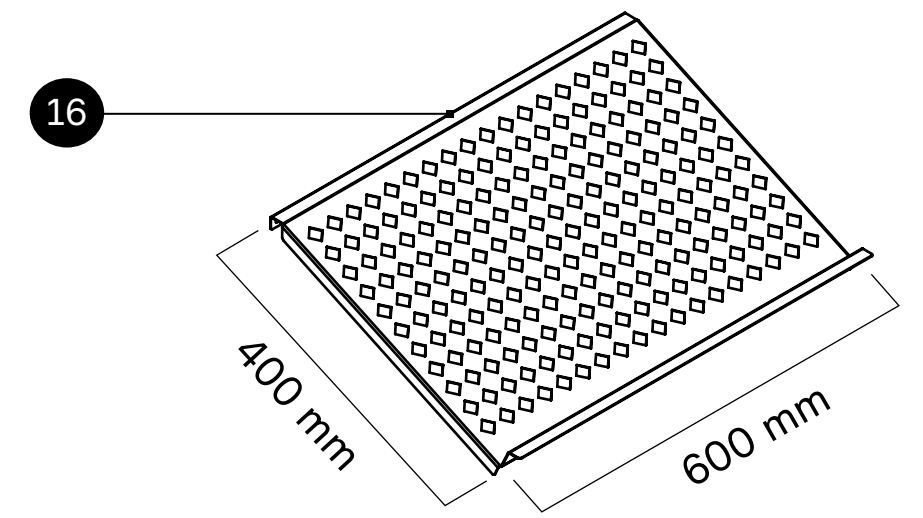
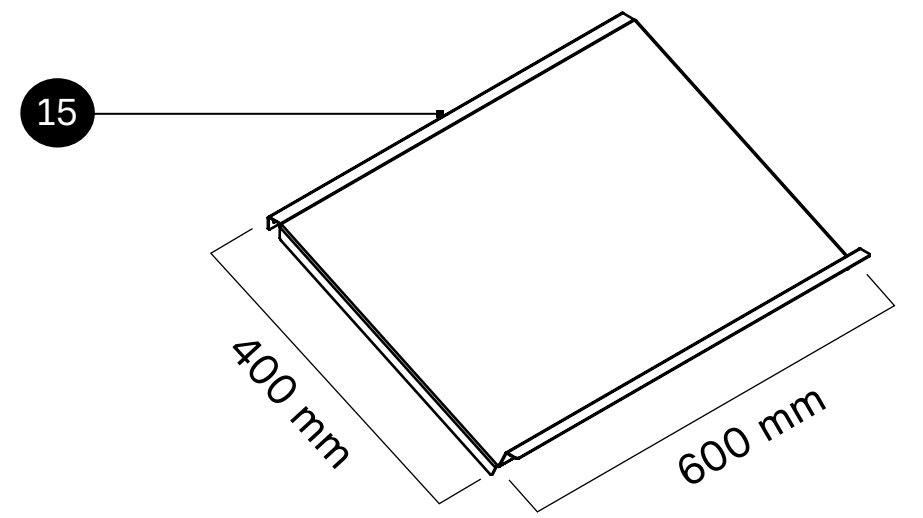

Stairs / Plateau

Click the number to get details

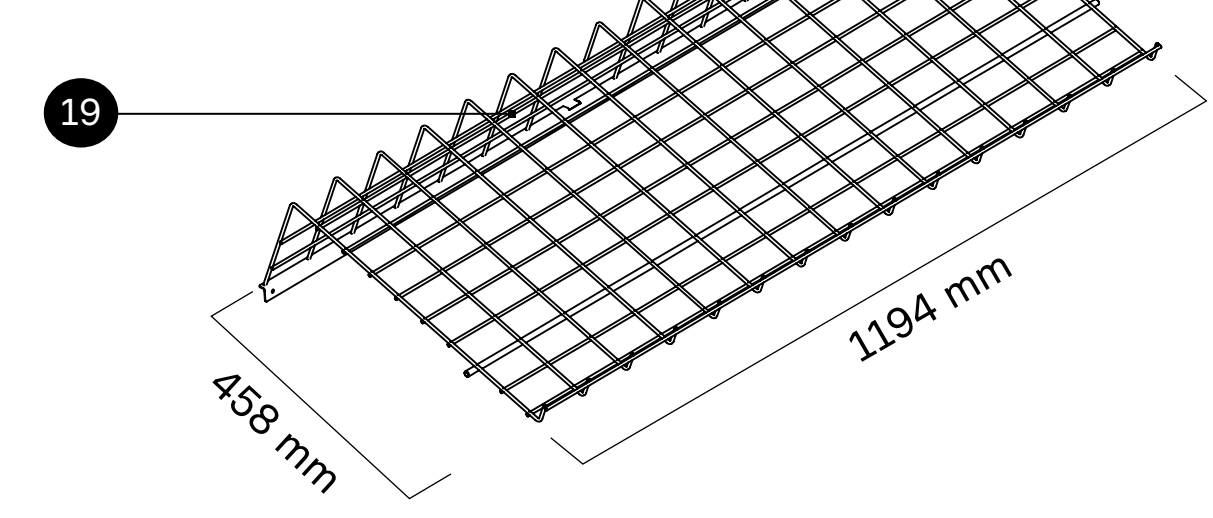
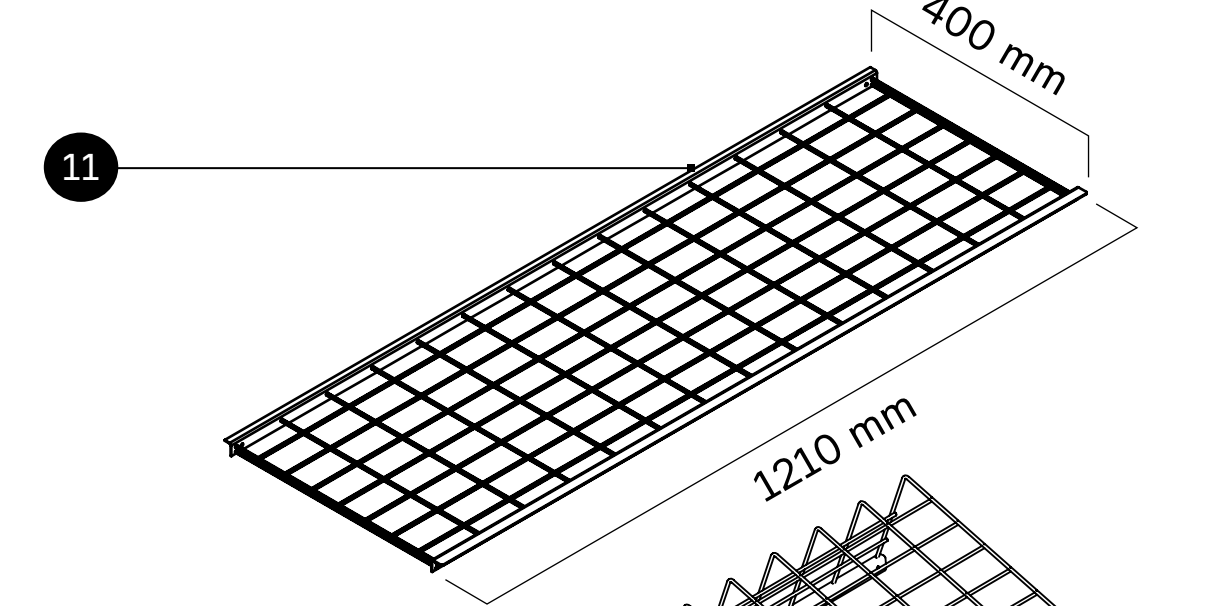

Accessories

Superstructure
Stairs

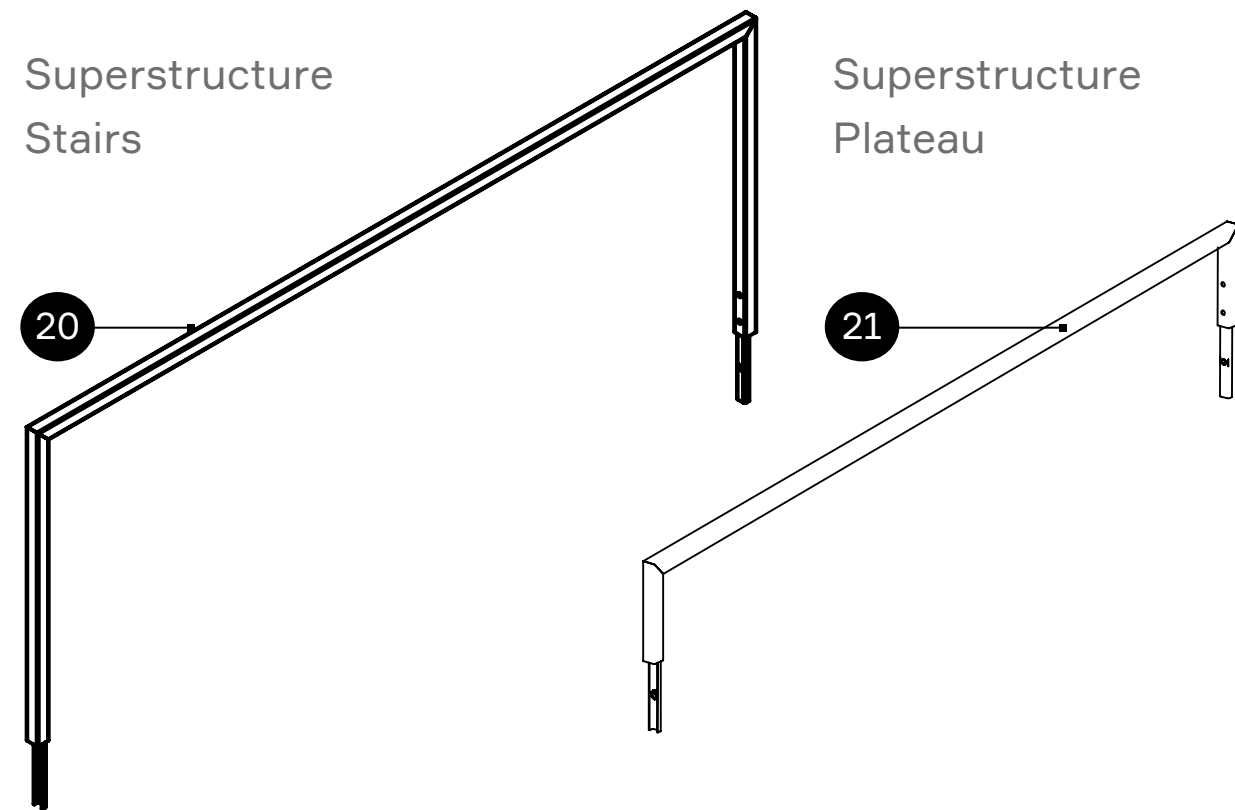

Hinged
baskets

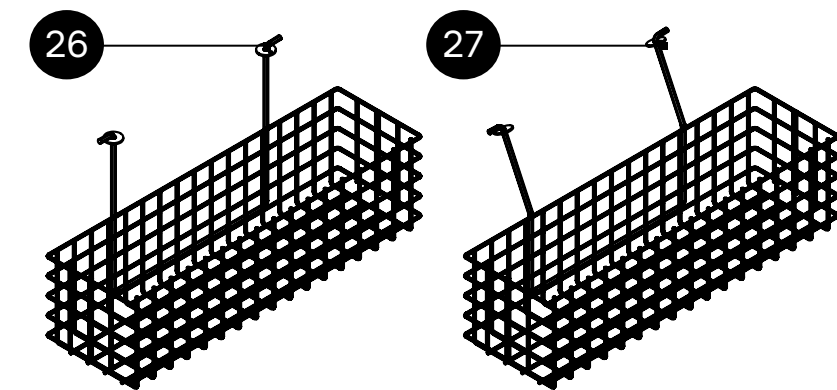

Hinged promo
panels

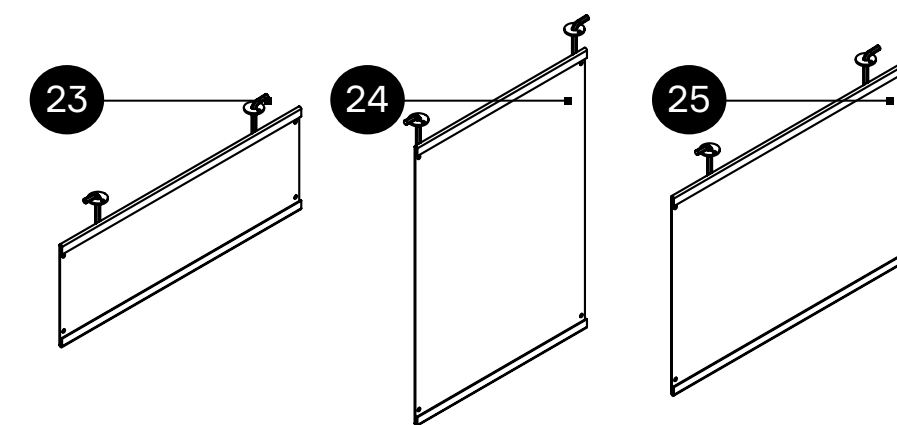

Superstructure
Trapez L

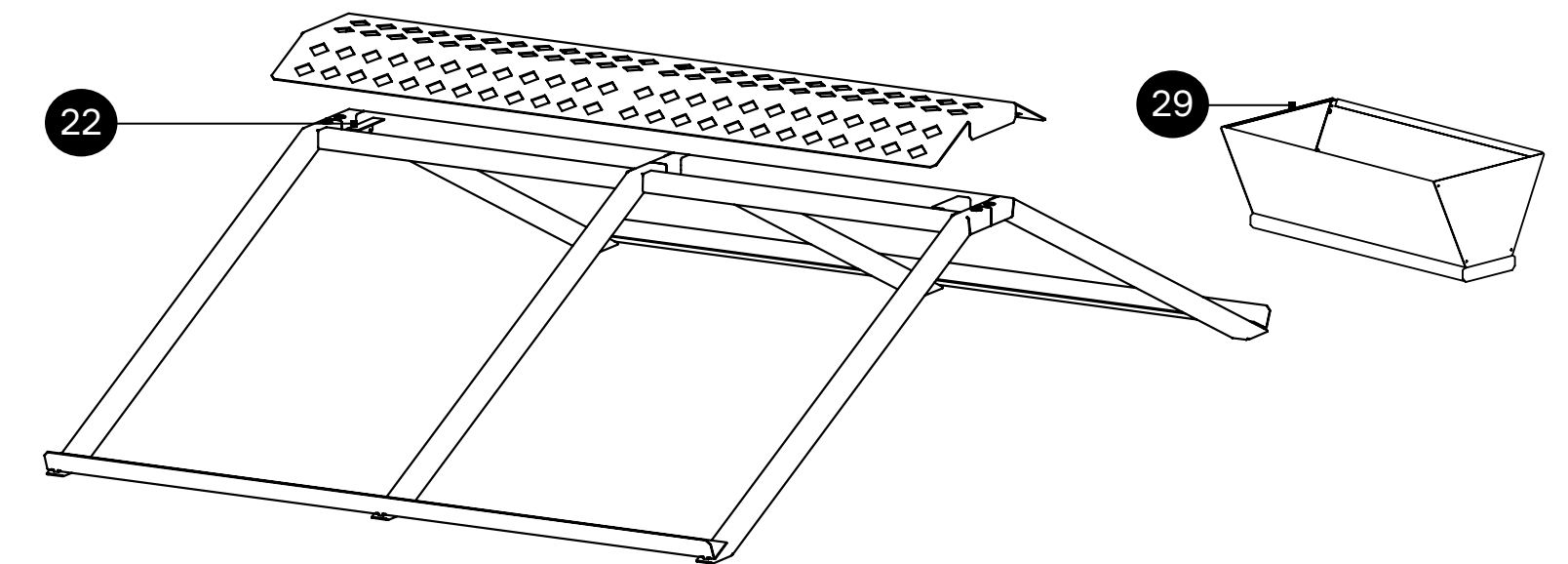

Easily assemble elements into Greora family modules

Article	Elements	Stairs	Storey	Plateau	Trapez L	Trapez S	BOX Wire	BOX Acrylic	BOX Plywood
Basic elements									
1	1018-385-K3	Framework Stairs	1						
2	1018-497-K3	Framework Storey		1					
3	1018-409-K3	Framework Plateau			1				
4	1018-496-K3	Trapez L				1			
5	1018-550-K3	Trapez S					1		
6	1022-660-K3	BOX Wire						1	
7	1022-659-K3	BOX Acrylic							1
8	1022-658-K3	BOX Plywood							
Framework support									
9	4037-007-04	Insert adjustable	4	4	4		4	4	4
10	4001-292-46	Wheel with stopper		4	4	4		4	4
Shelves									
11	1018-386-K3	Straight wire wide	•		•				
12	1017-574-K3	Straight sheet shelf		•	•				
13	1017-575-K3	Straight perforated shelf		•	•				
14	1017-725-K3	Straight wire shelf		•	•				
15	1017-571-K3	Inclined sheet shelf		•	•				
16	1017-572-K3	Inclined perforated shelf		•	•				
17	1017-762-K3	Inclined wire shelf		•	•				
Accessories									
18	1017-902-K3	Base straight wire shelf			•				
19	1018-504-K3	Base Inclined wire shelf	•		•				
20	1018-411-K3	Superstructure Stairs	•						
21	1018-412-K3	Superstructure Plateau			•				
22	1018-498-K3	Superstructure Trapez L				•			
23	1018-129-K3	Promo panel 300x108 mm	•	•					
24	1018-127-K3	Promo panel 300x213 mm	•	•					
25	1018-128-K3	Promo panel 213x300 mm	•	•					
26	1018-118-K3	Straight hinged basket	•	•					
27	1018-119-K3	Inclined hinged basket	•	•					
28	1018-387-K3	Reinforced shelf			•				
29	1017-869-K3	Basket Trapez L				•			
30		Sound module	•	•	•				
31	1016-783-10	Wooden box 600x400x150	•	•	•	•			
32	1016-784-10	Wooden box 300x600x150	•	•	•	•			
33	1016-786-10	Wooden box 600x400x100	•	•	•	•			

 main elements  optional elements

Greora's RAL Identity

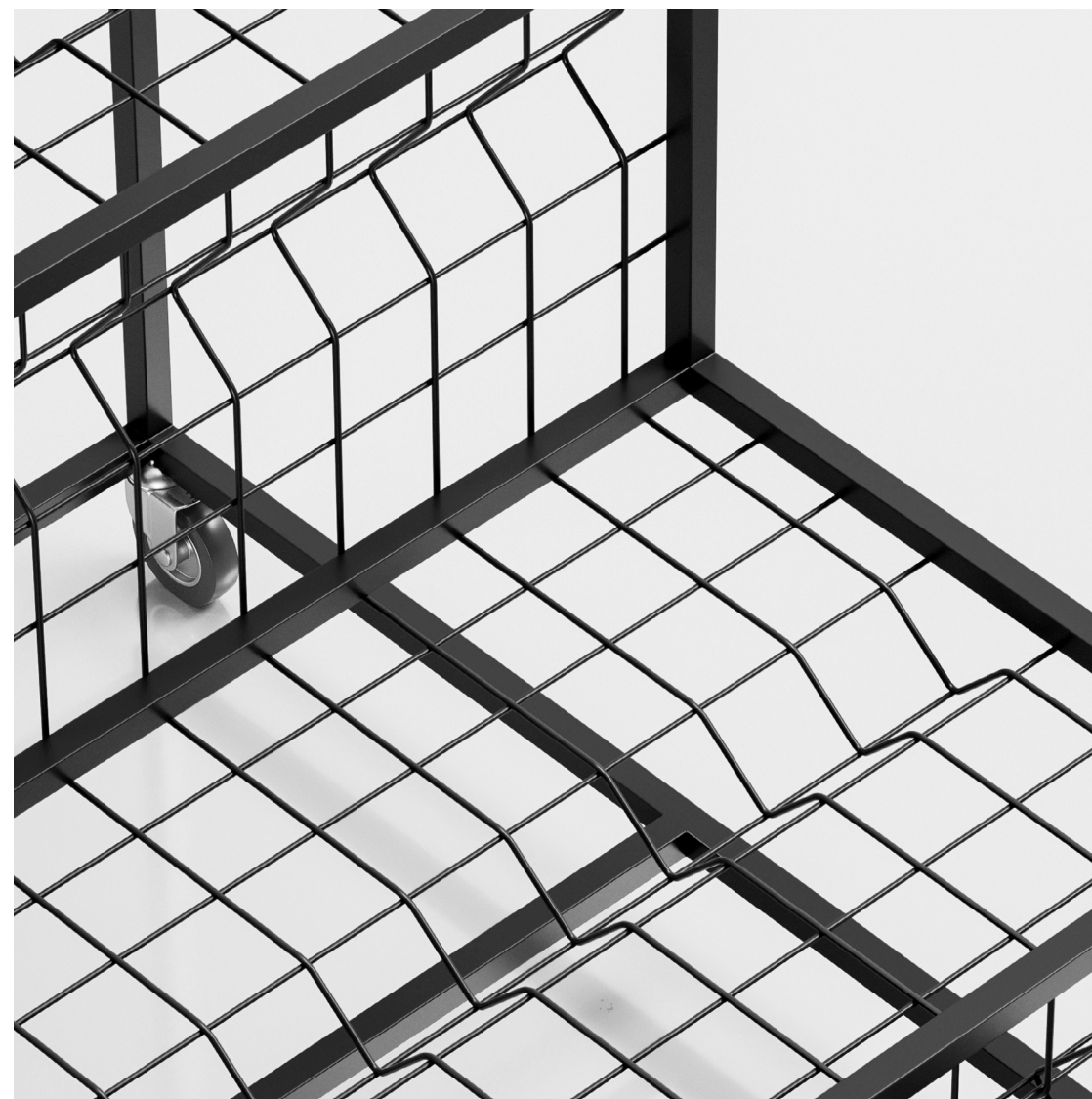

Inborn RAL 9005



Tender RAL 9016



Exect RAL 2009

MODERN EXPO

Head Office
Modern Expo

Lutsk, Ukraine

T +380 (332) 78 95 00

info@modern-expo.com

modern-expo.eu



**UKRAINIAN
DESIGN
THE VERY
BEST OF**

Greora — winner in the nomination
«Retail design» at the UKRAINIAN
DESIGN THE VERY BEST OF 2020
competition

Office in Poland
Lublin
T +48 (81) 744 50 50
biurohandlowe@modern-expo.pl

Office in Germany
Berlin
T +49 (0) 171 222 12 93
officeberlin@modern-expo.de

Office in France
Wissous
T +33 (7) 67 03 03 35
contact@modern-expo.com

Office in UK
London
T +44 (0) 7534 635 103
uk.sales@modern-expo.com

Office in the Middle East
Dubai, UAE
T +971 (0) 4 557 8311
uae@modern-expo.com