

M²DERN EXPO

WINE & ALCOHOL

#newretail equipment

archiw

Archiw family

encourages atmosphere that impulse purchases

In search of a new vision that combines industrial and natural production we create Archiw – a new vision of Wine Products zone

Archiw family consists of 3 kinds of modules and wide range of additional accessories, that give plenty of abilities to create spectacular atmosphere and helps transform impressions into shopping experiences

Archiw's design comes from architectural forms. Lightweight construction, thin shelves and customized accessories create a dynamic and atmospheric display of products. The bearing function is provided by a light square tubular framework. Shelves and accessories may be conveniently replaced and rearranged for novelty effect. Transform the store layout quickly with mobile modules. Mobile modules are equipped with reliable wheels. Archiw may be a powerful cross-selling tool, creating a great impulse to buy.

- > Variable
- > Pop-up solution
- > Cascading presentation
- > Modular design for size roll-out
- > Easy reconfiguration
- > Cross-selling capabilities
- > Lightweight construction
- > Pool of accessories for customized construction
- > Contrasted authentic colors as a standard
- > Indoor usage

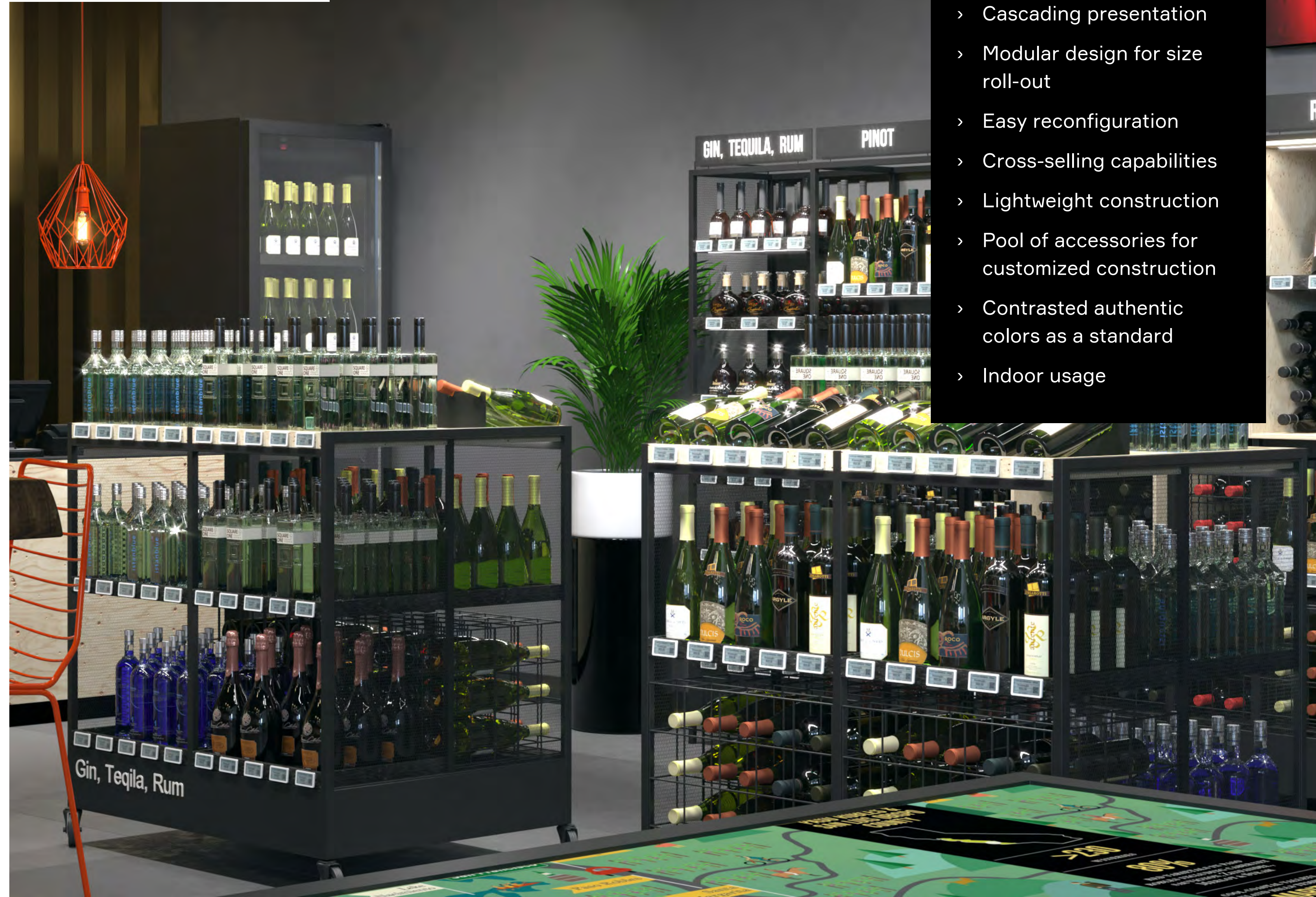

Facade

Multi-level shelving for adjustable exposition

Block

3-level multifunctional module

Platform

Mobile promo display

Click the name to get details

BLOCK



FACADE

PLATFORM



Facade

Multi-level shelving for adjustable exposition

Inspiring contact point of your wine zone

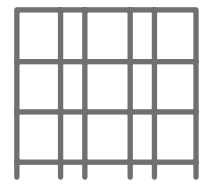

Multi-level exposition

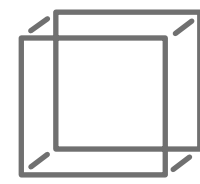

Folding frame base



Adjustable arrangement of bottles

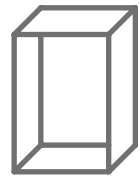

Plywood box inserts

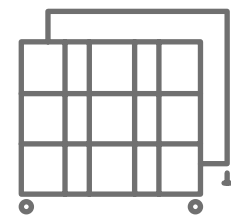

Mobile / Stationary

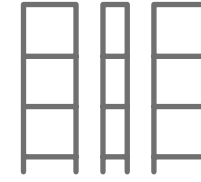

Modular



Wall / Free Standing unit

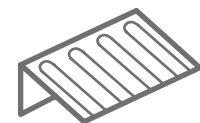

Pool of accessories for adjustable construction



Size

Facade Stationary

1940x420x1888

Facade Mobile

1940x420x1851

Materials

metal square pipe

metal sheet

mesh

wire

plywood

Customize your Facade

Examples of sets

BASIC

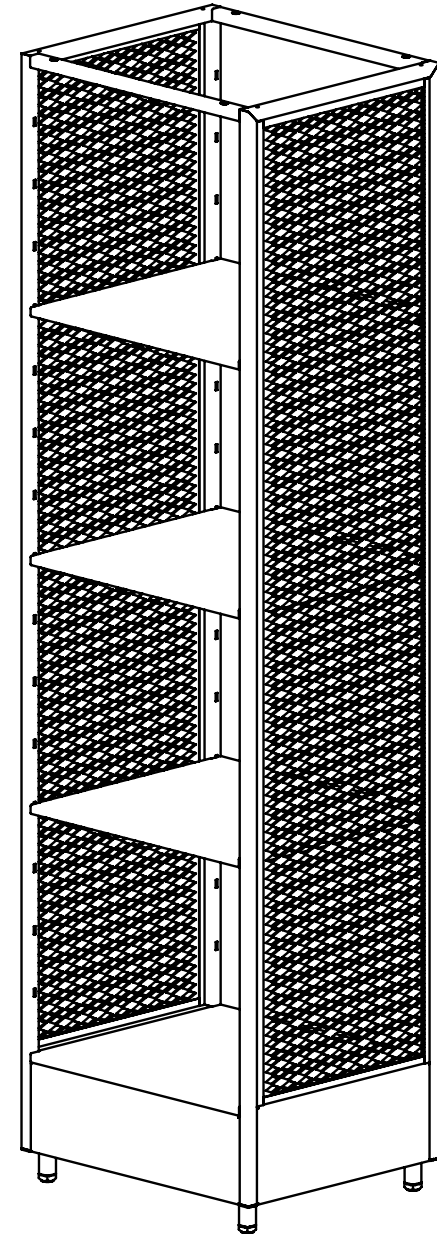

- 1 Basic section Facade Stationary Wide — 1
- 9 Sidewall Fasade — 1
- 14 Insert adjustable — 4
- 18 Metal shelf wide — 3
- 19 Bracket — 6

EXTRA

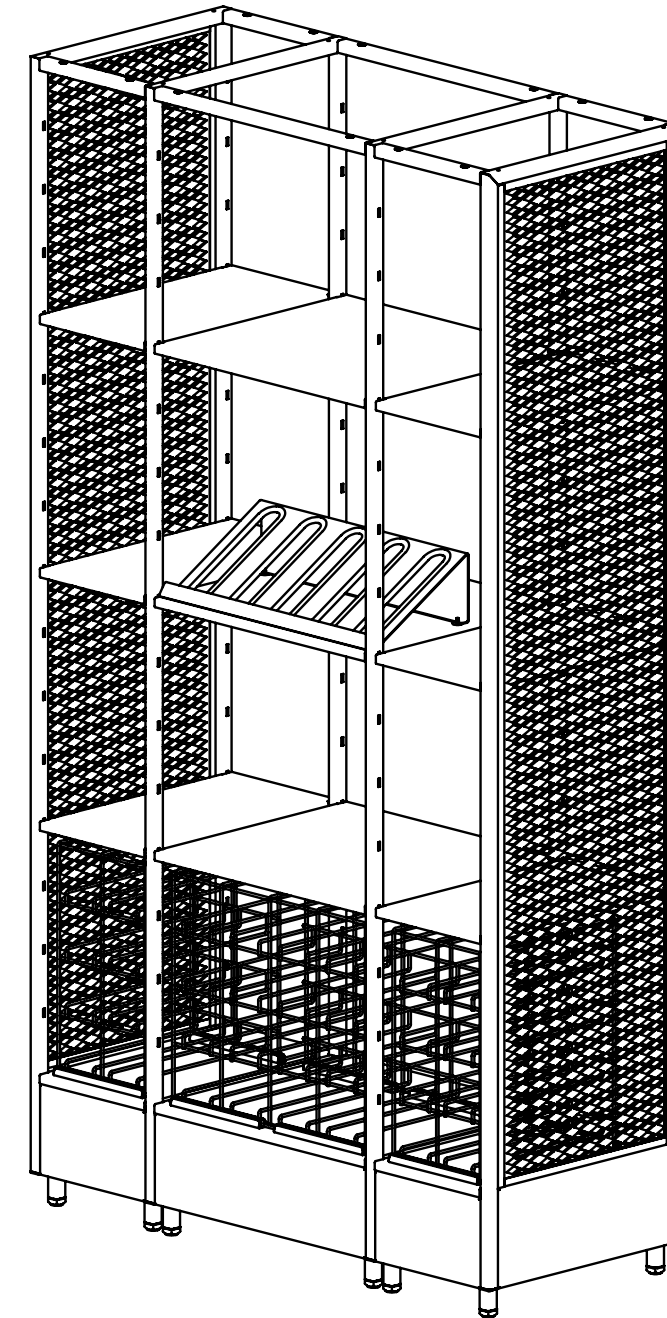

- 2 Basic section Facade Stationary Narrow — 1
- 3 Extension section Facade stationary Wide — 1
- 4 Extension section Facade stationary Narrow — 1
- 9 Sidewall Fasade — 1
- 14 Insert adjustable — 12
- 17 Metal shelf narrow — 6
- 18 Metal shelf wide — 3
- 19 Bracket — 18
- 26 Wide Shelf expositor inclined low — 1
- 27 Wire expositor narrow — 2
- 28 Wire expositor wide — 1

ADVANCED

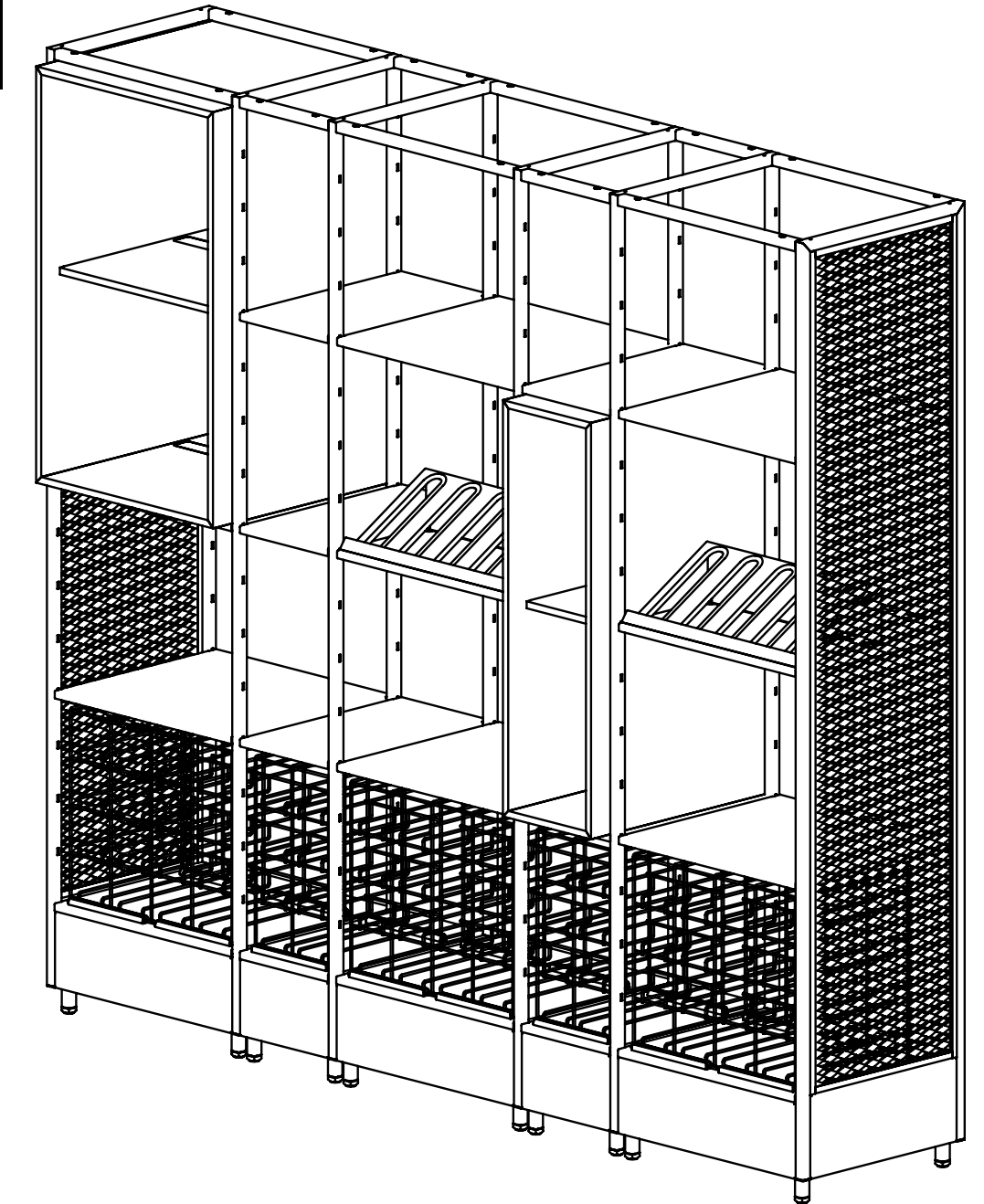

- 1 Basic section Facade Stationary Wide — 1
- 4 Extension section Facade stationary Narrow — 2
- 3 Extension section Facade stationary Wide — 2
- 9 Sidewall Fasade — 1
- 14 Insert adjustable — 20
- 17 Metal shelf narrow — 5
- 18 Metal shelf wide — 8
- 19 Bracket — 26
- 20 Plywood box narrow — 1
- 21 Plywood box wide — 1
- 25 Wide Shelf expositor inclined low — 2
- 27 Wire expositor narrow — 2
- 28 Wire expositor wide — 3

Click the number to get details

Structure of Facade & Load capacity

Facade Stationary

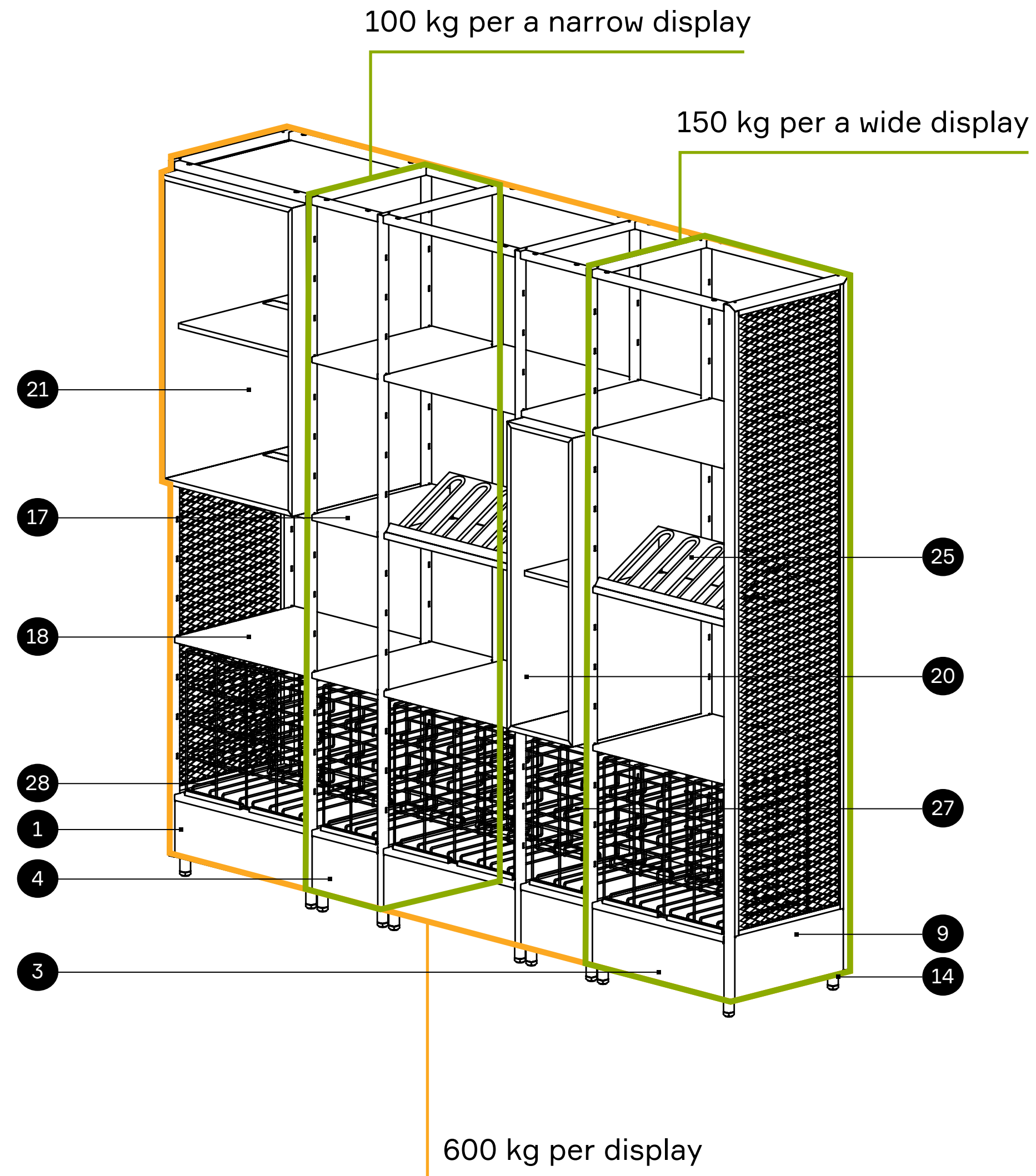

Facade Mobile

Click the number to get details

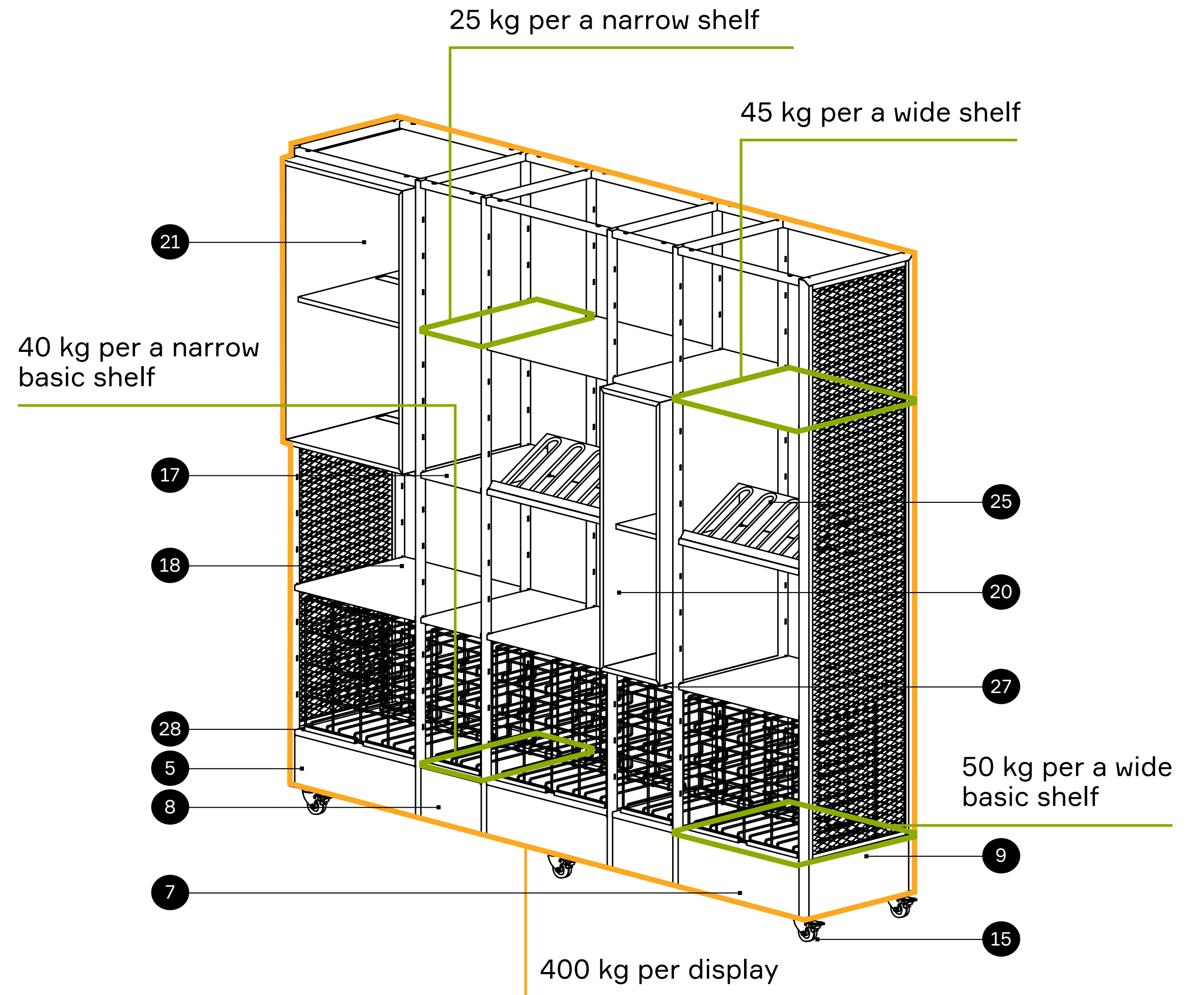

Quantity of wheels:
 1-3 sections — 4 pcs.;
 4+ sections — 4 pcs. for basic and last extension sections + 2 pcs. for every 3 middle extension sections.

Technical details

Facade Stationary

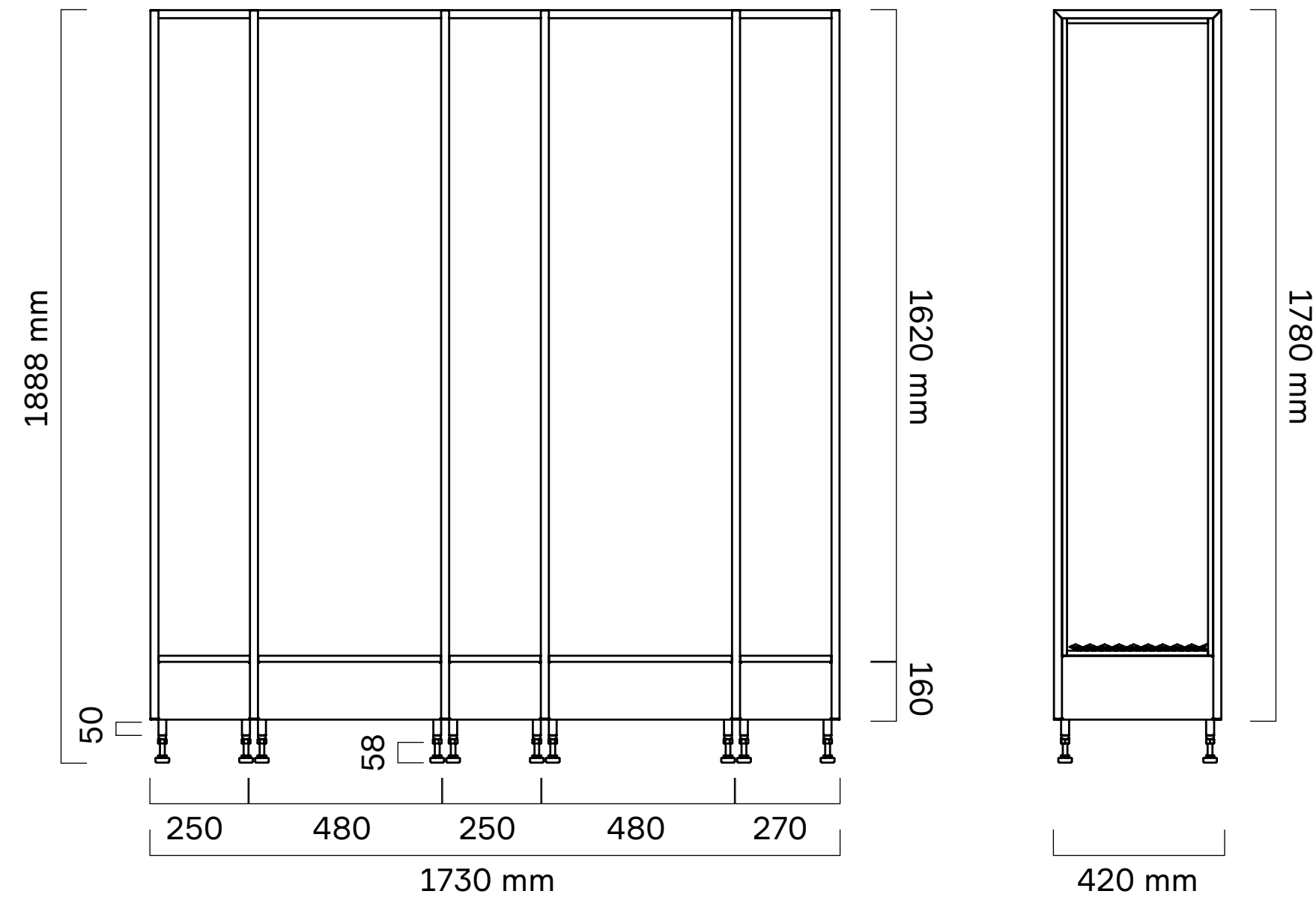

Facade Mobile

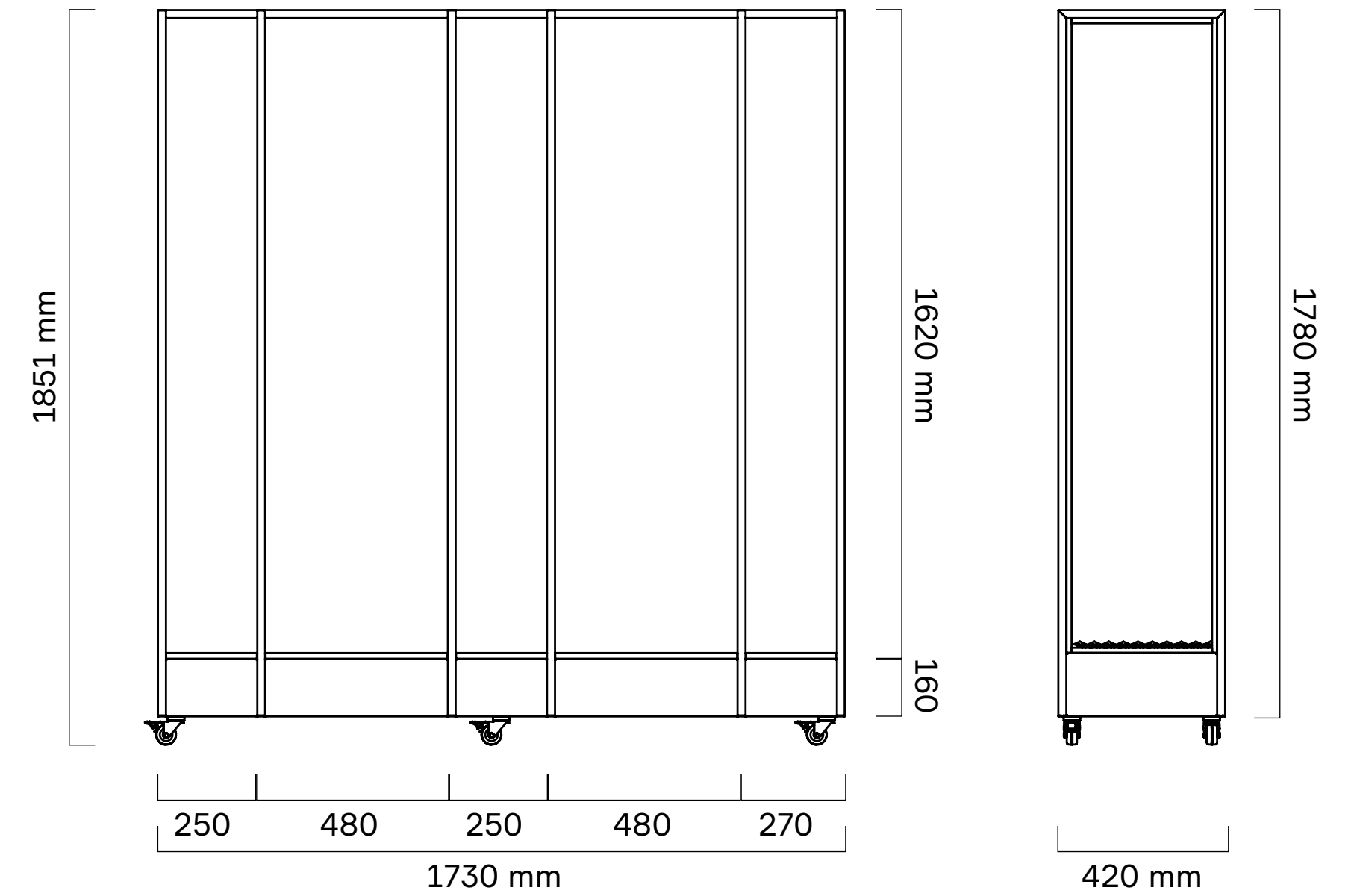

Click the number to get details

Folding framework

The only thing you need for bringing the framework together is cruciate screwdriver

Easy to assemble. Easy to disassemble. Easy to store

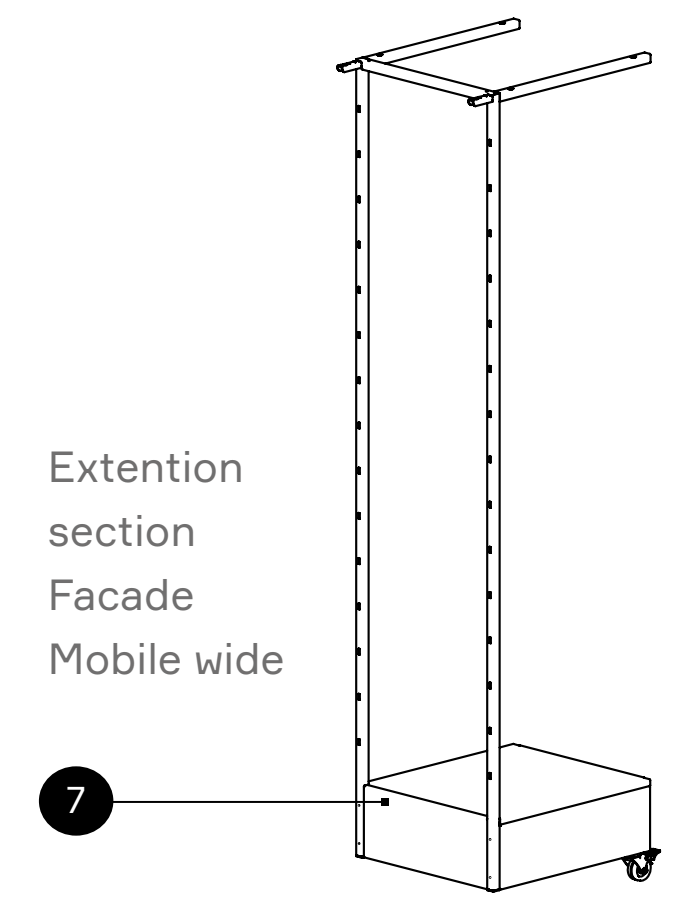
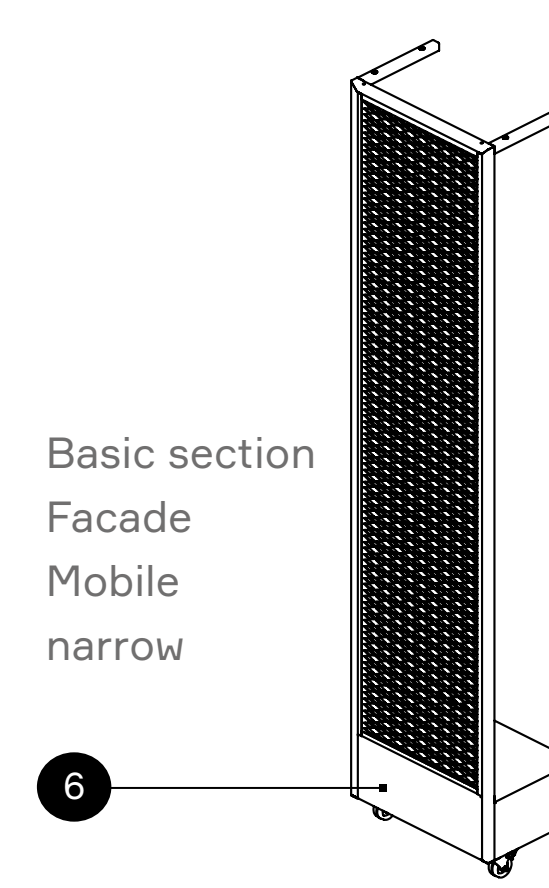
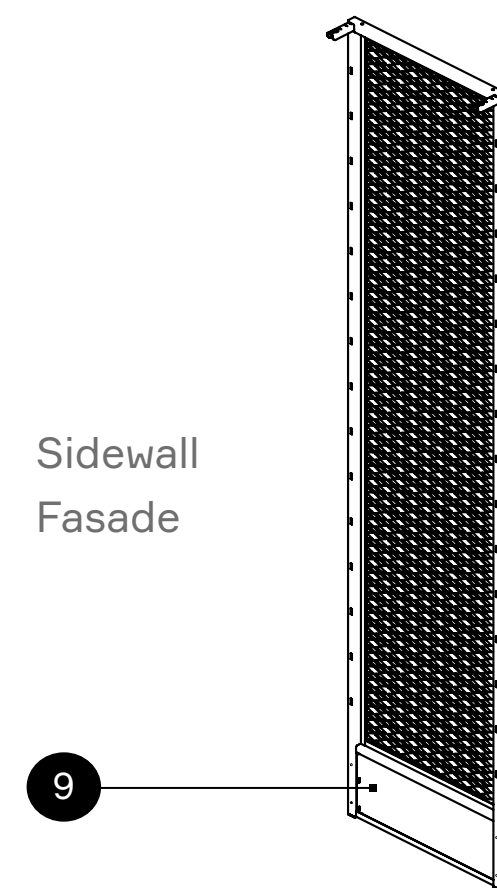
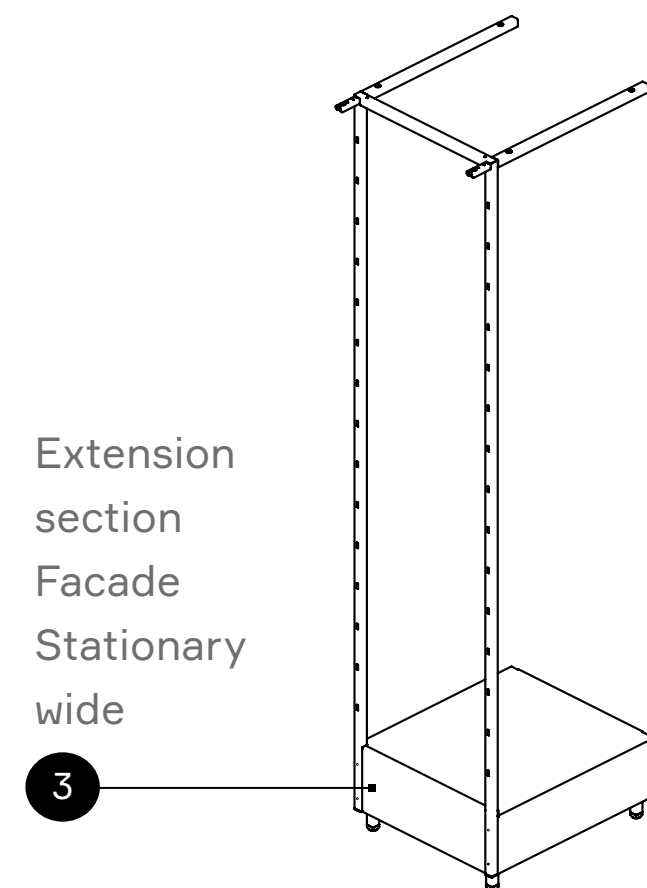
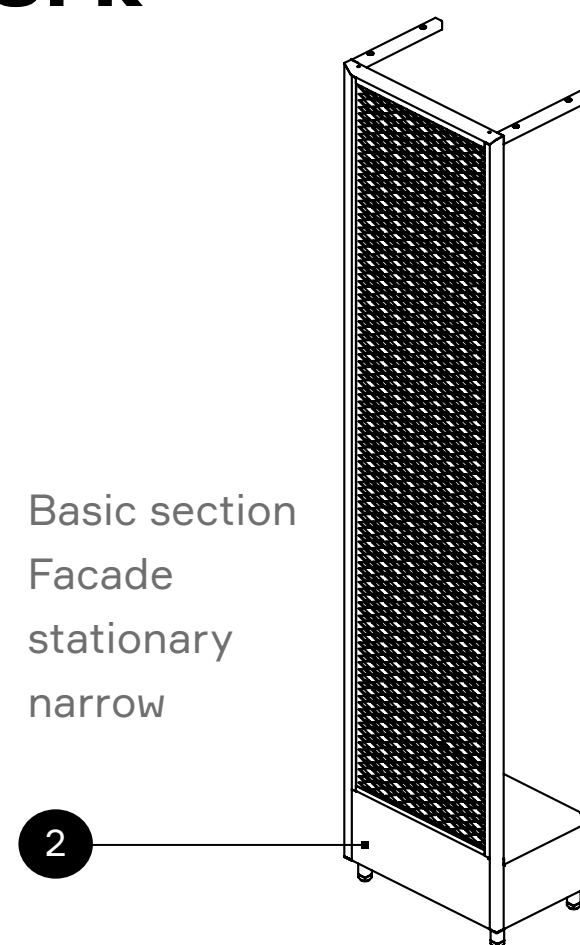

Block

3-level multifunctional module

Inspiring contact point of your wine zone

Size

1061x800x1086

Materials

metal square pipe

mesh

plywood

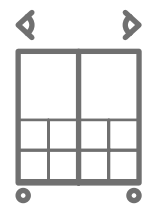

360°
presentation

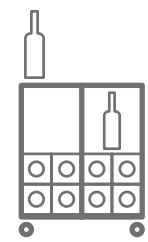

3-level
exposition



Horizontal / vertical /
inclined arrangement of
bottles

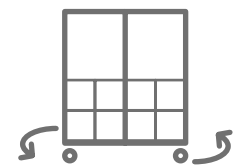

Mobile

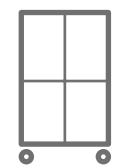

Free-standing
unit



Plywood
shelves

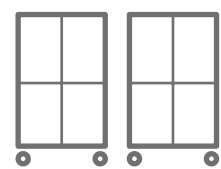

Modular

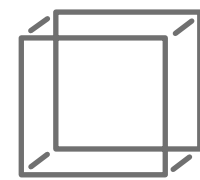

Folding frame
base



Customize your Block

Examples of sets

BASIC

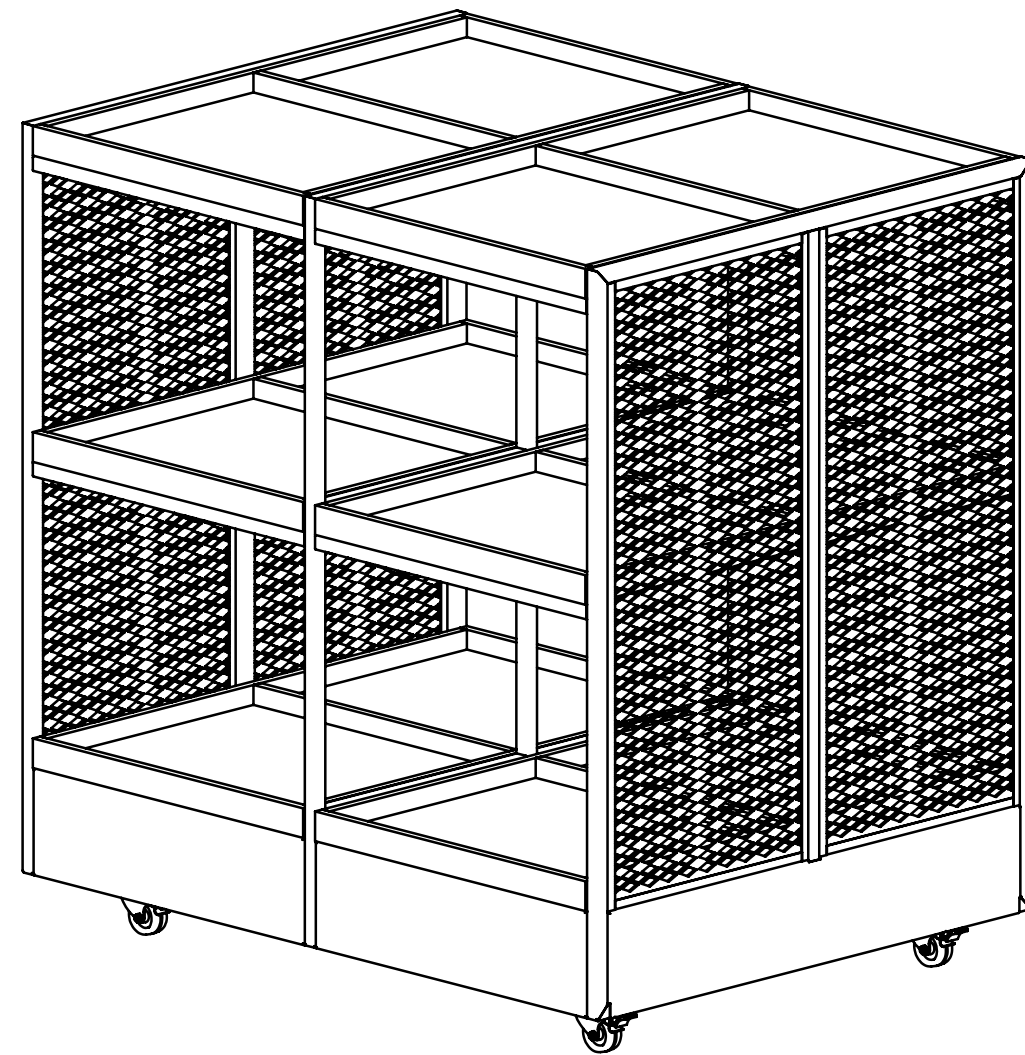

- 10 Basic section Block — 1
- 11 Extension section Block — 1
- 12 Sidewall Block — 1
- 15 Wheel with stopper — 4
- 22 Plywood shelf — 6

ADVANCED

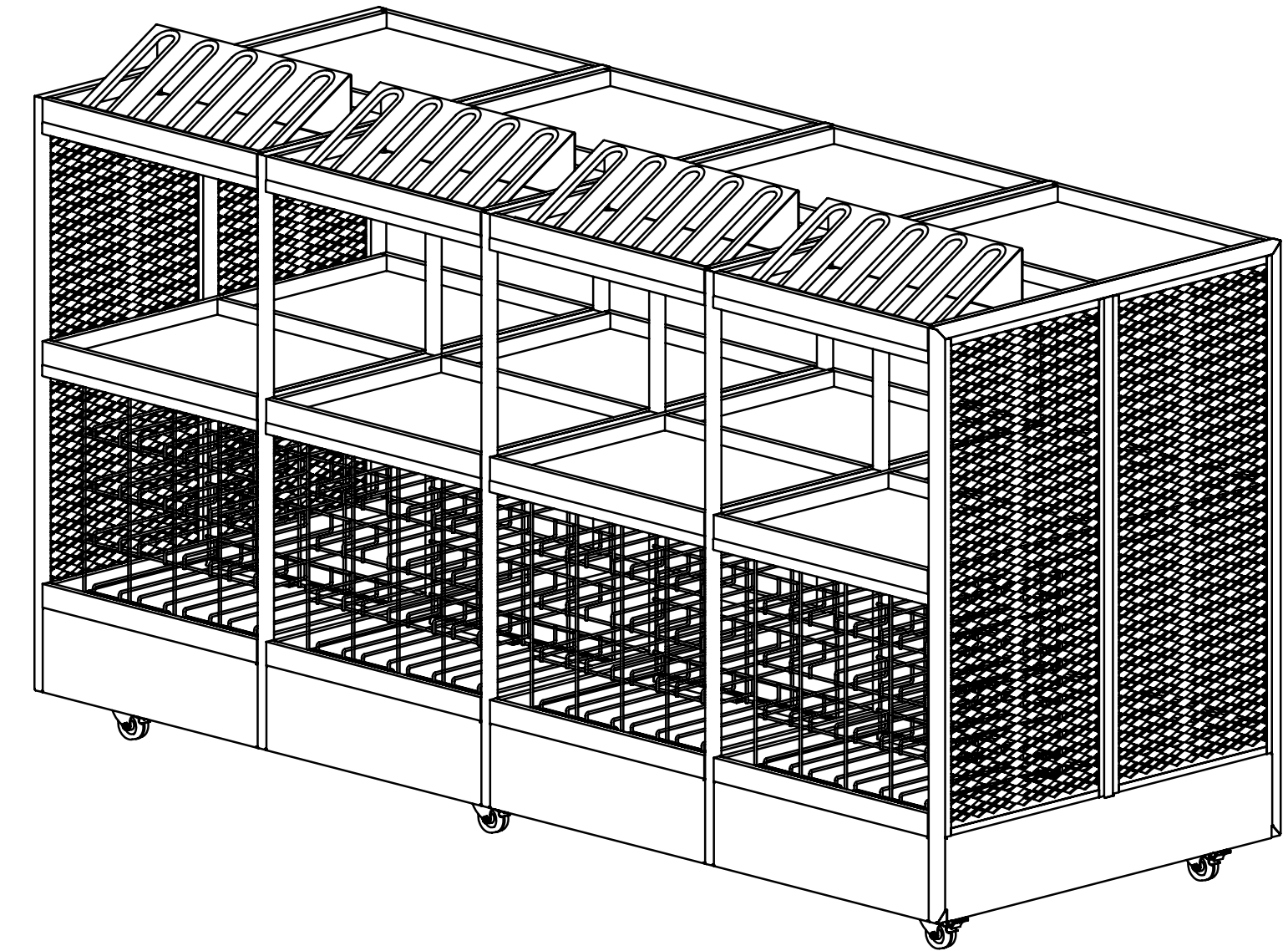

- 10 Basic section Block — 1
- 11 Extension section Block — 3
- 12 Sidewall Block — 1
- 15 Wheel with stopper — 6
- 22 Plywood shelf — 12
- 25 Wide Shelf expositor inclined low — 4
- 28 IncWire expositor wide — 4

Click the number
to get details

Technical details

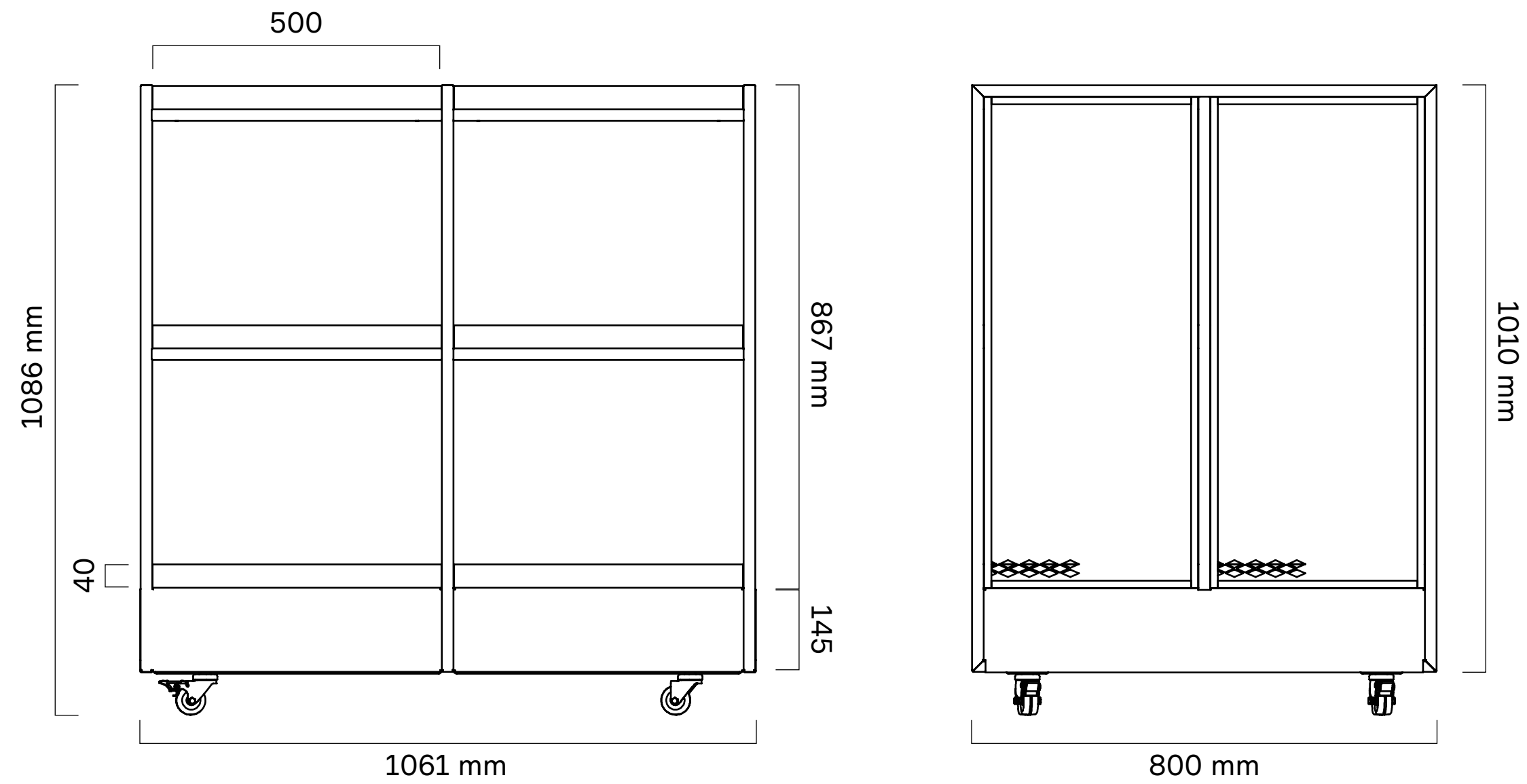

Structure of Block

Click the number to get details

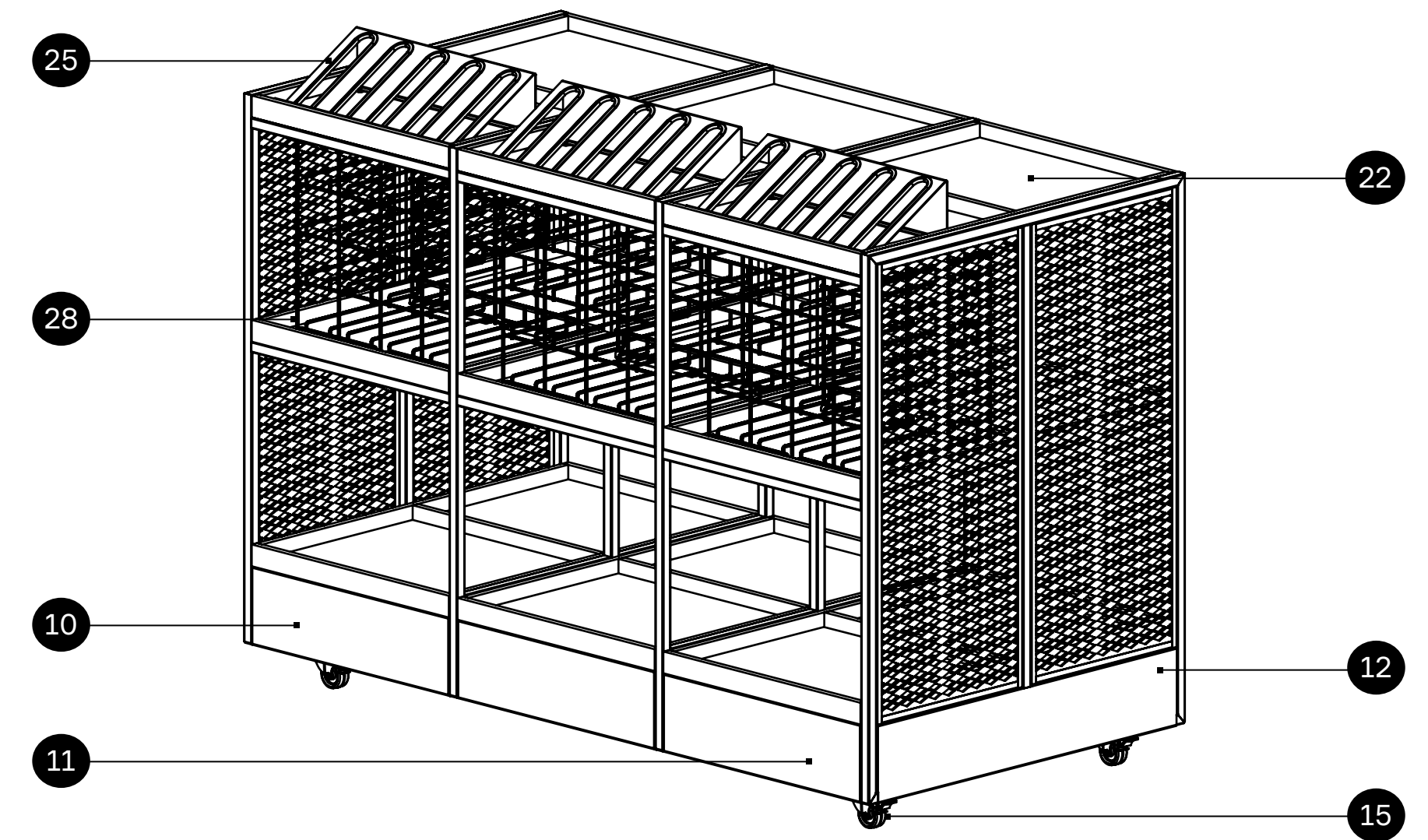

Folding framework

Easy to assemble.
Easy to disassemble.
Easy to store

Basic section Block

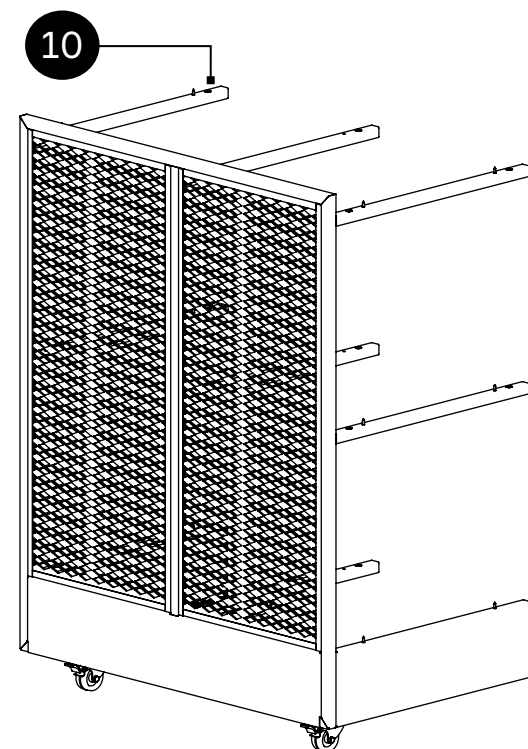

Extension section Block

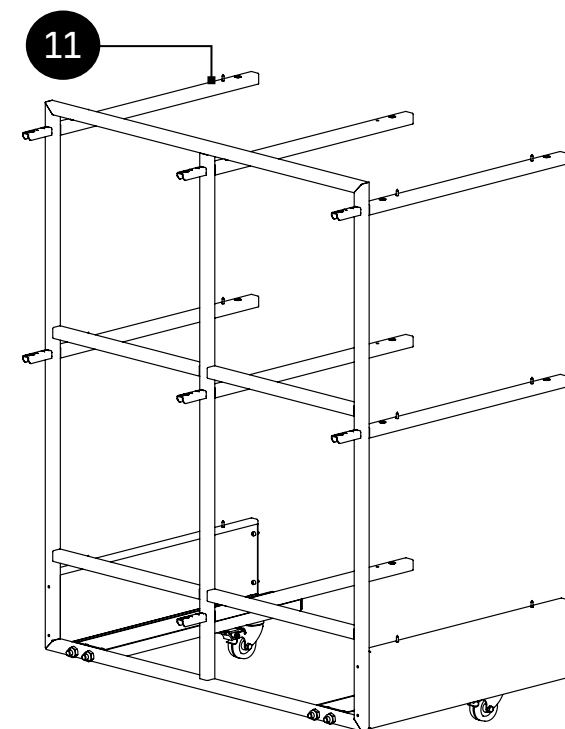

Sidewall Block

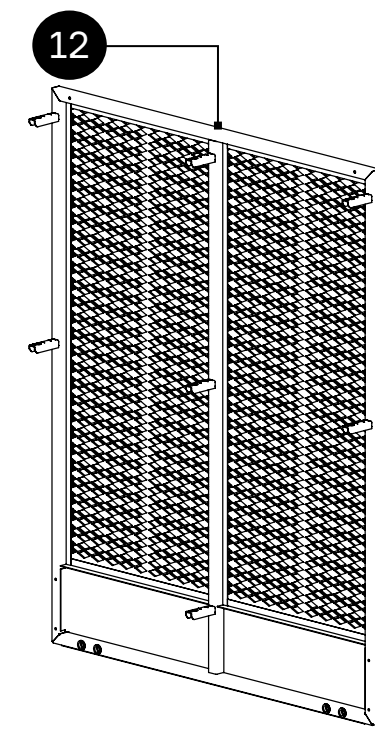

Load capacity

75 kg per level

225 kg per display

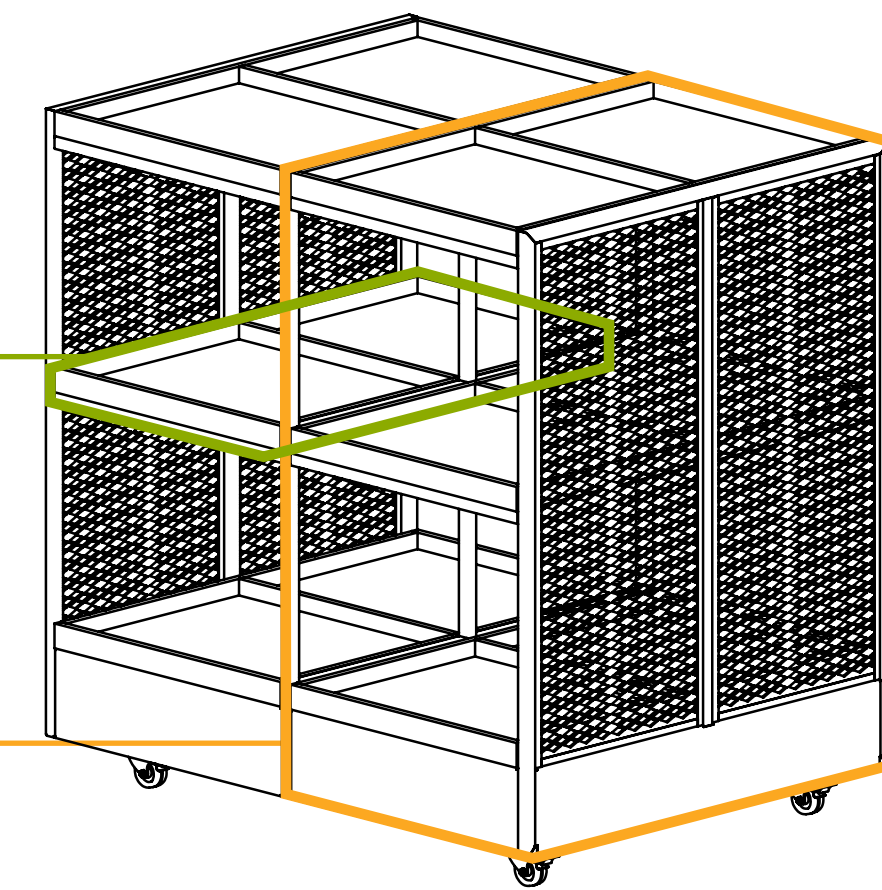

Platform

Mobile promo display

Inspiring contact point of your wine zone



360°
presentation



3-level
exposition

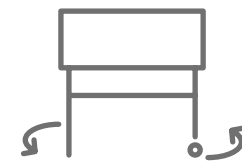

Mobile



Island
unit

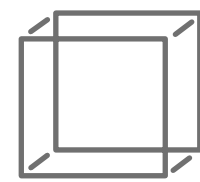

Folding frame
base



Reinforces
tempered glass
surface



Easy
cleaning

Size

1050x800x1060

Materials

metal square pipe

mesh

plywood

tempered glass



Technical details

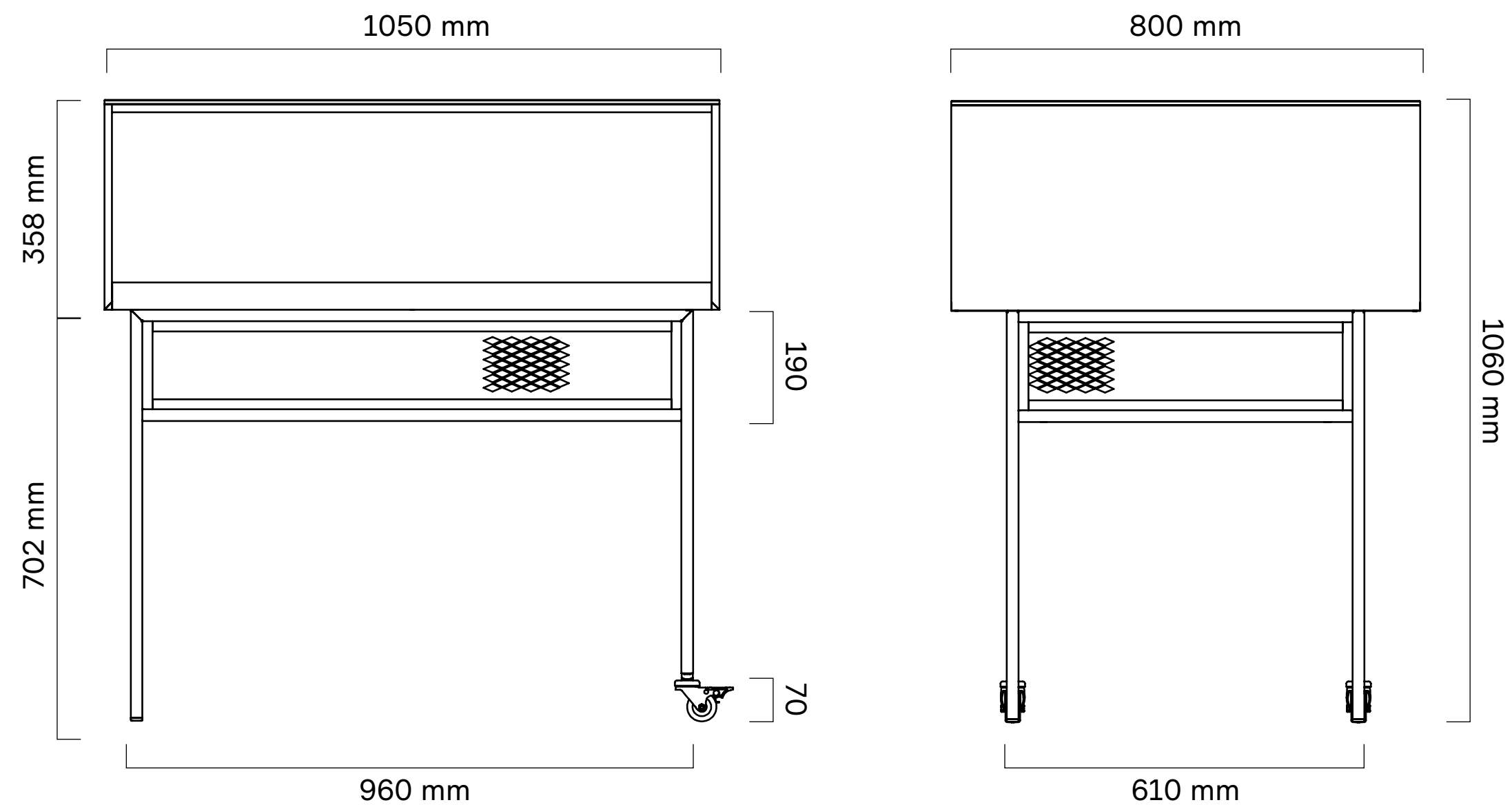

Structure of Platform

Click the number to get details

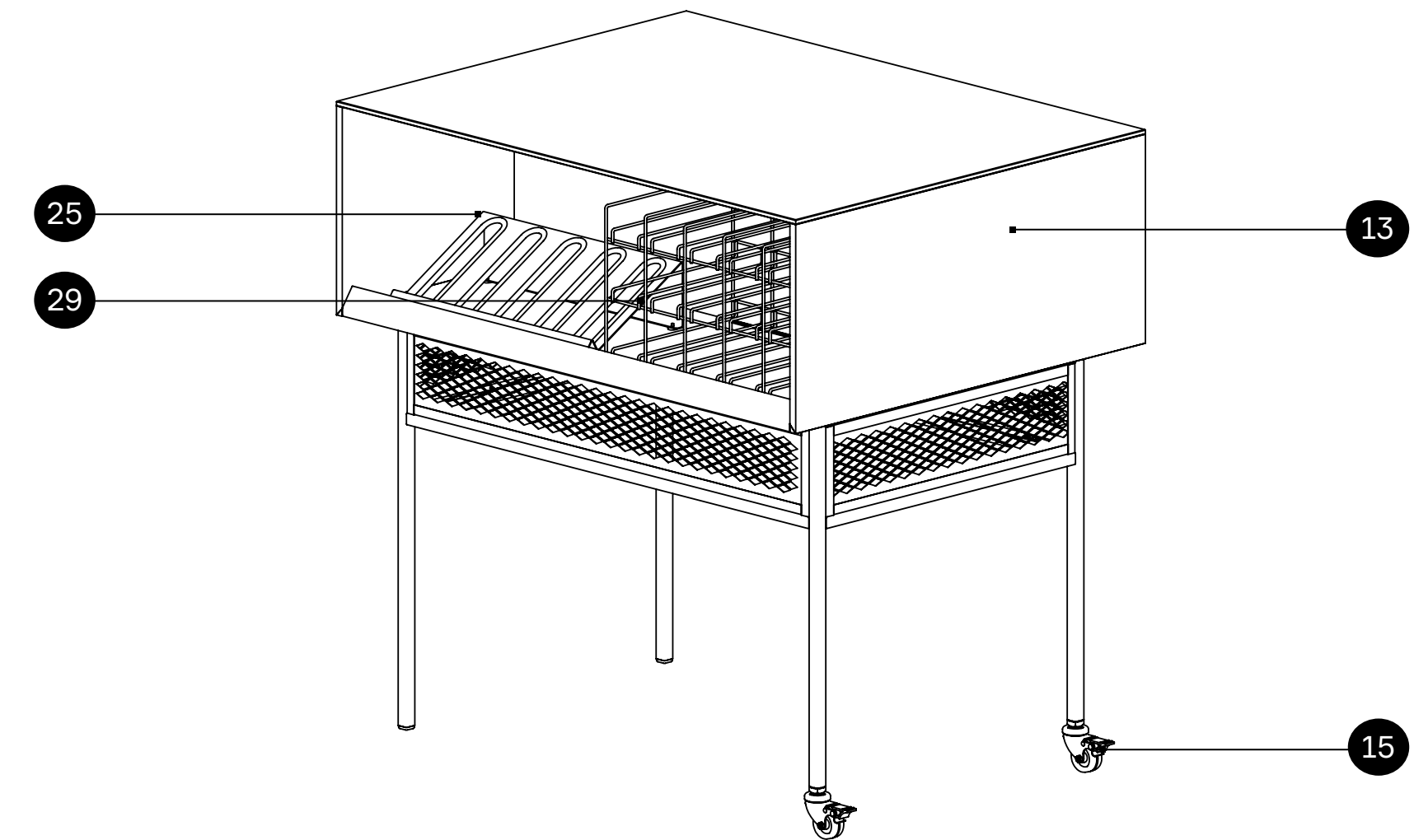

Folding framework

The only thing you need for bringing the framework together is cruciate screwdriver

Easy to assemble.
Easy to disassemble.
Easy to store

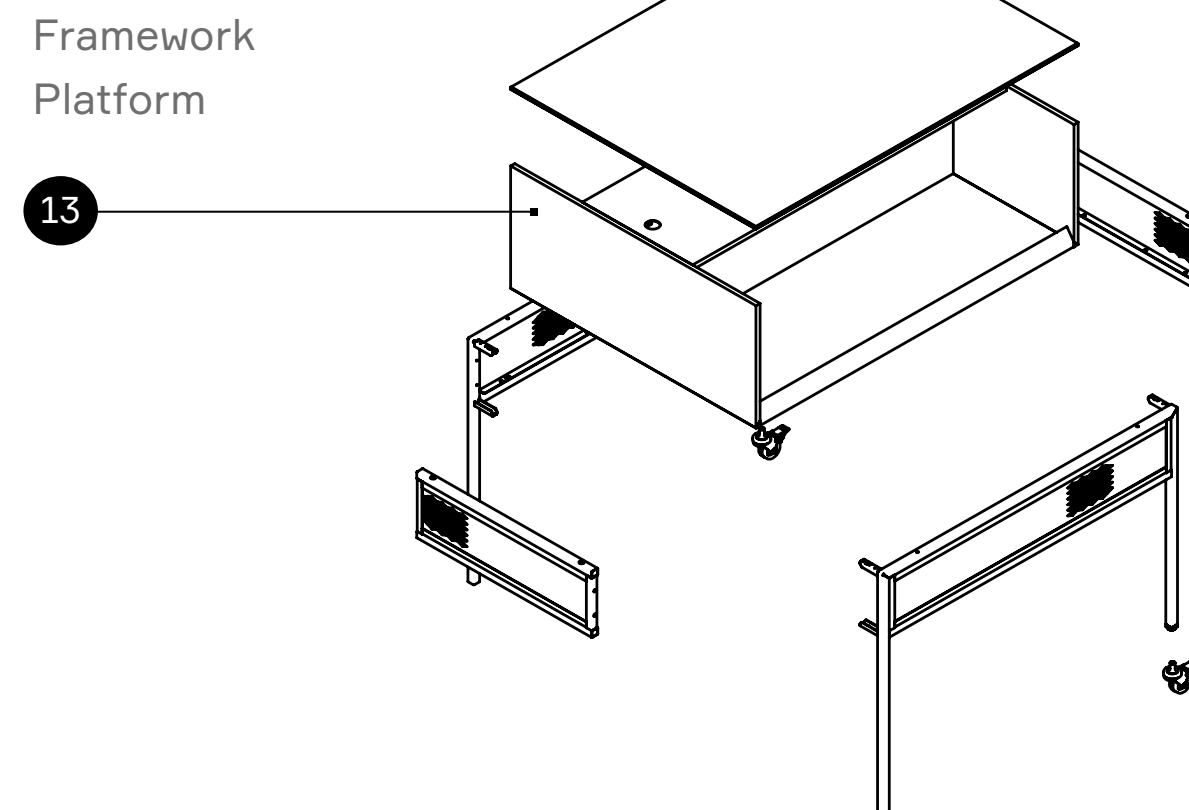

Load capacity

50 kg per level

150 kg per display

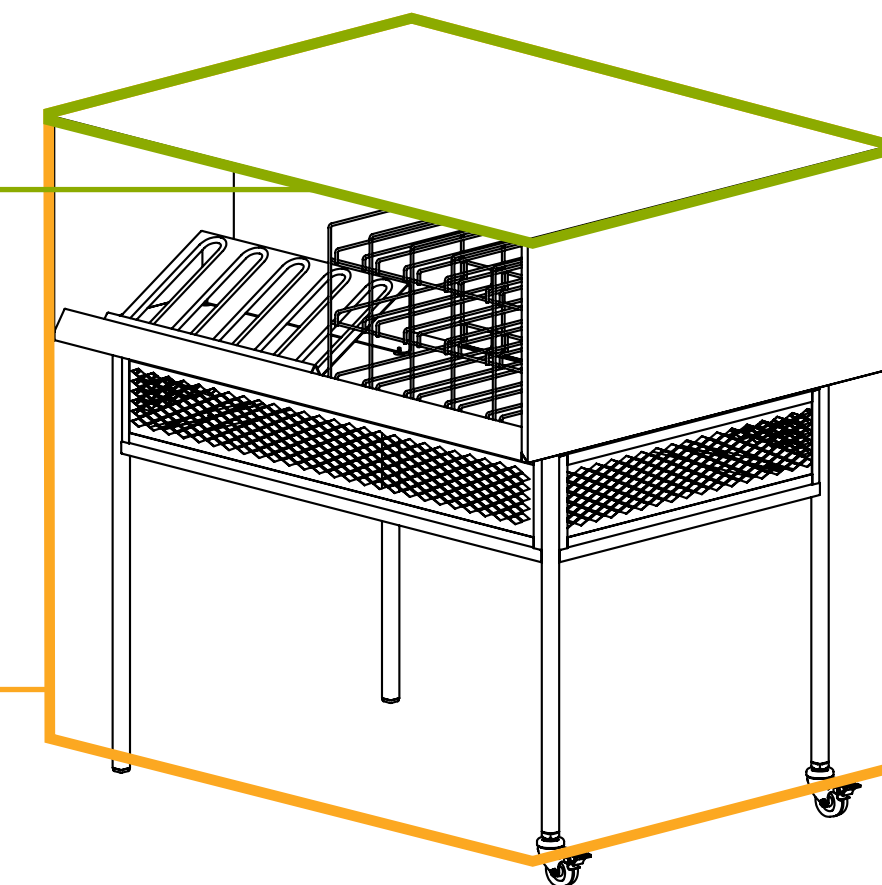

Types of shelves

Facade

Metal narrow shelf

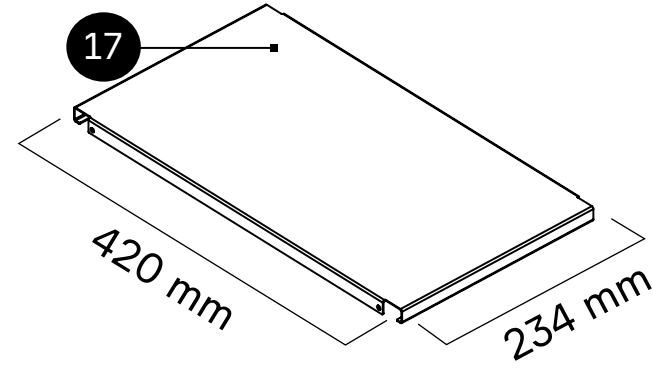

Metal wide shelf

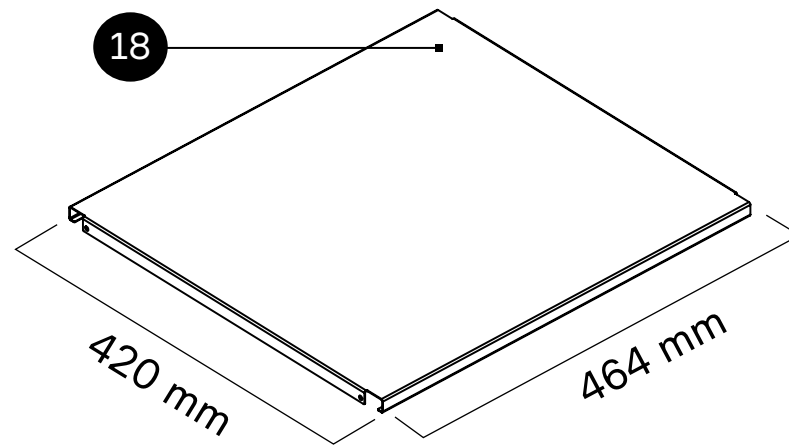

Bracket

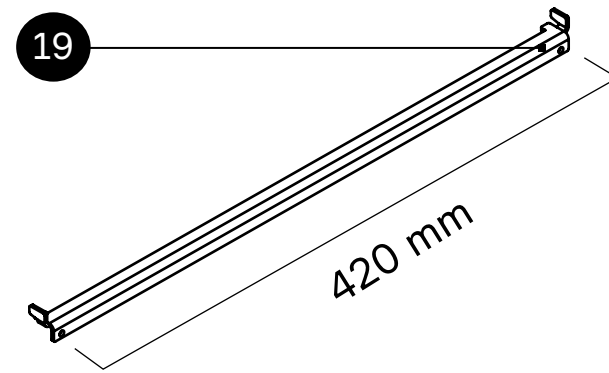

Plywood box narrow

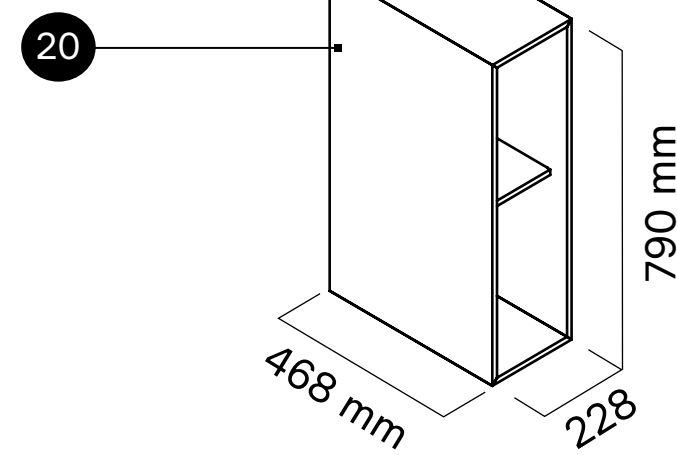

Plywood box wide

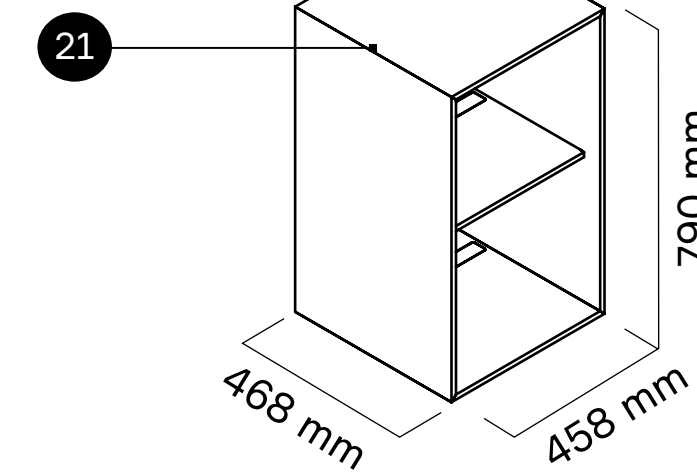

Block

Plywood shelf

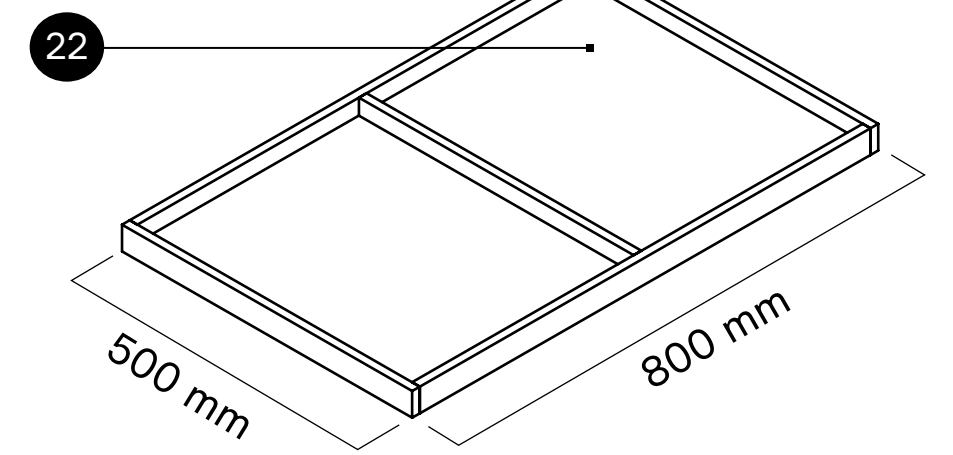

Click the number to get details

Accessories

Facade / Block / Platform

Wide box expositor inclined low
4 bottles, 30° presentation

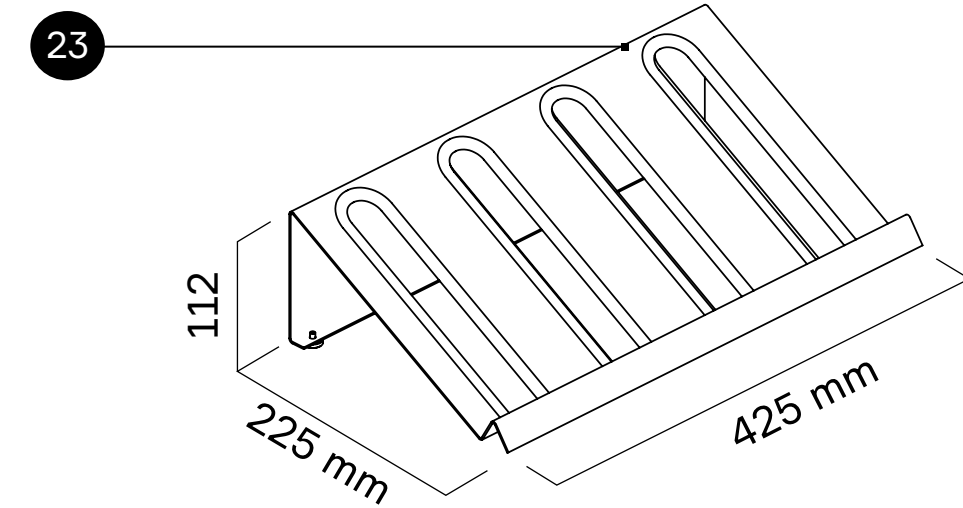

Wide box expositor inclined high
4 bottles, 45° presentation

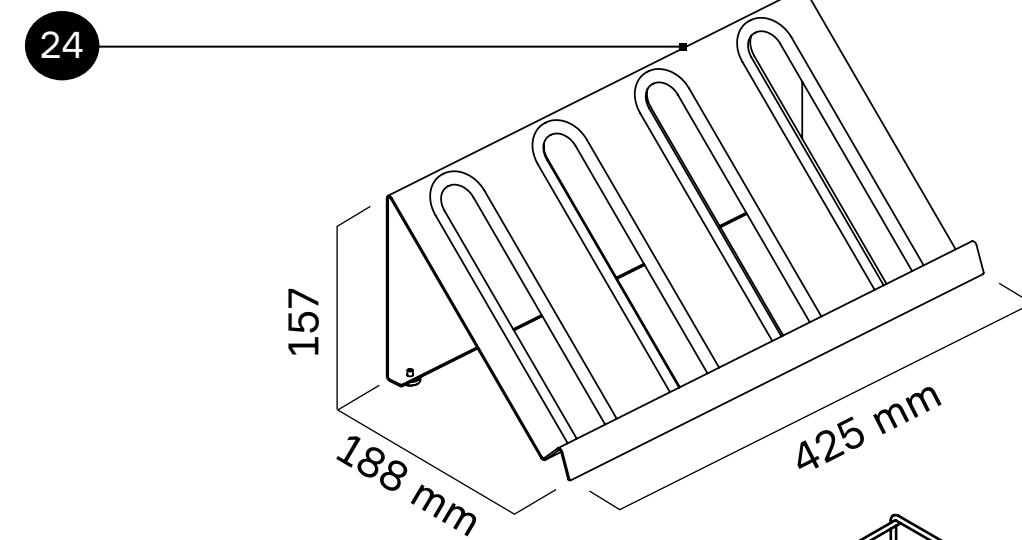

Wide Shelf expositor inclined low
5 bottles, 30° presentation

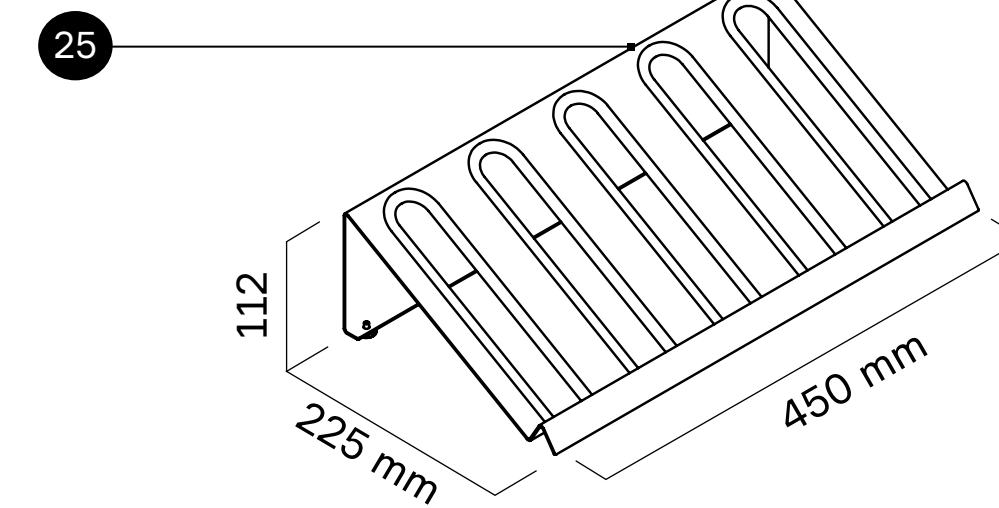

Wide Shelf expositor inclined high
5 bottles, 45° presentation

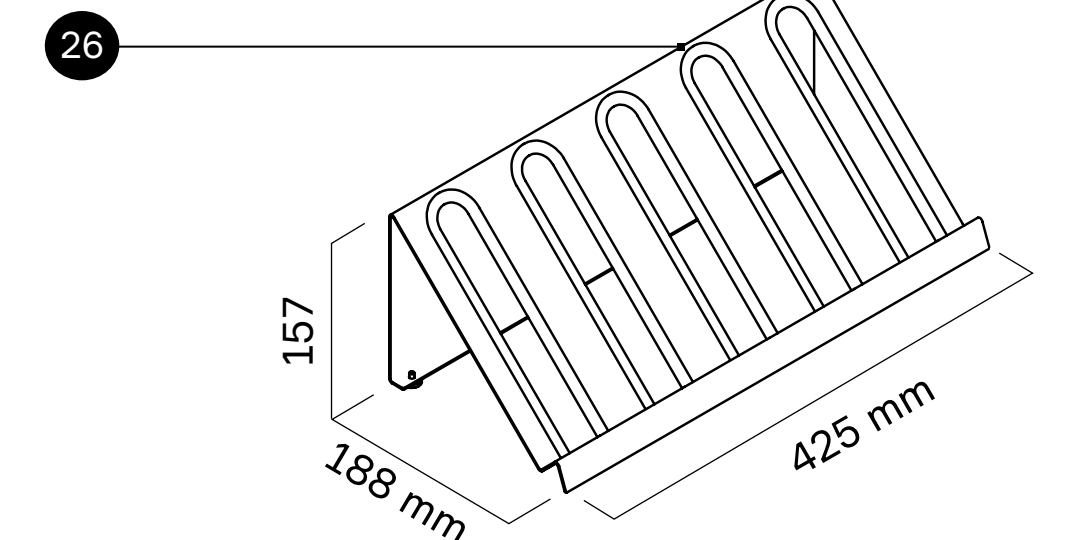

Facade / Block

Wire expositor narrow
8 bottles

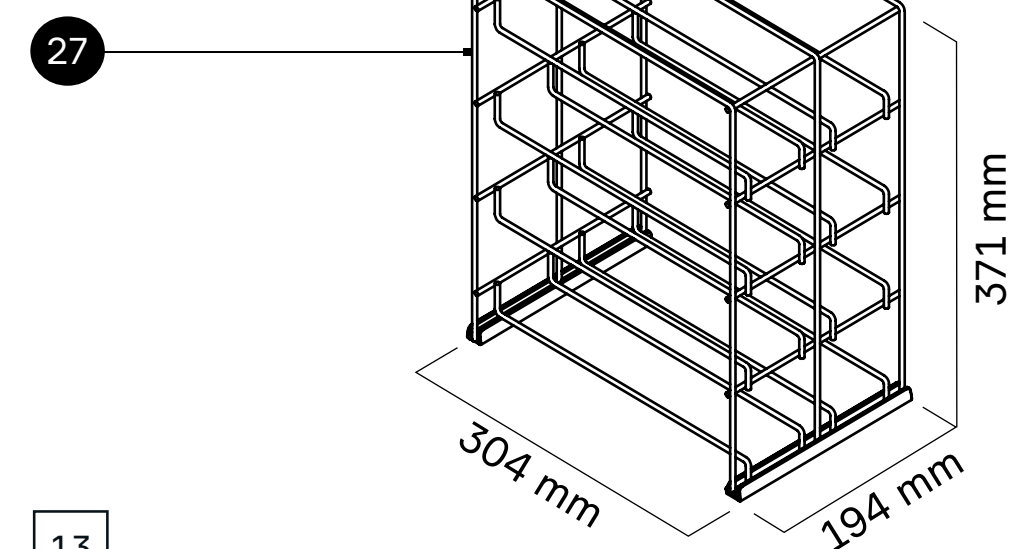

Wire expositor wide
16 bottles

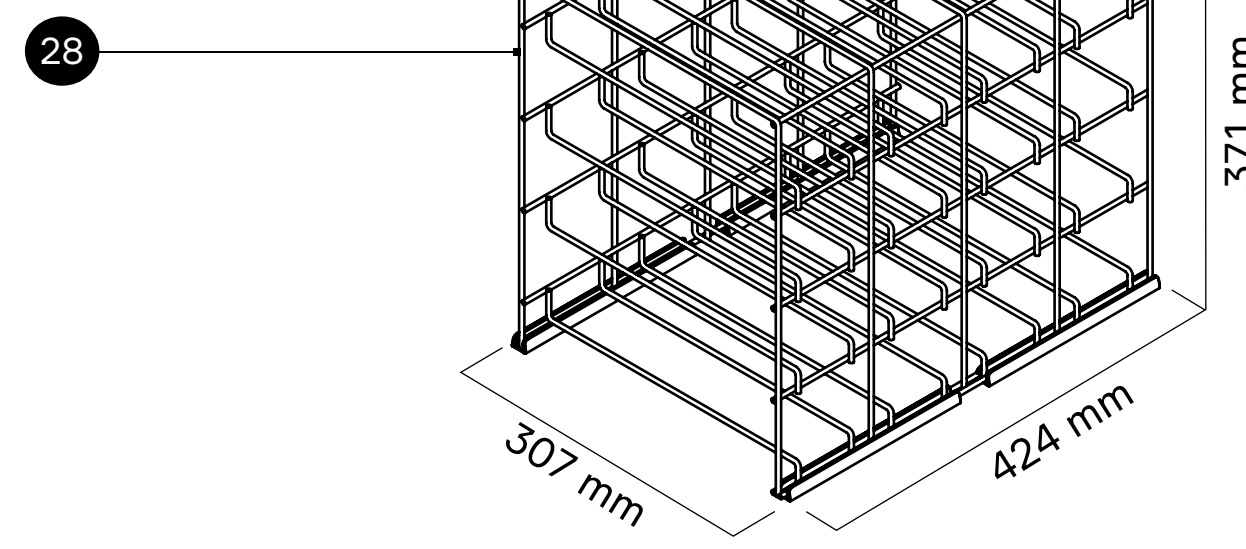

Wide shelf wire expositor low
10 bottles

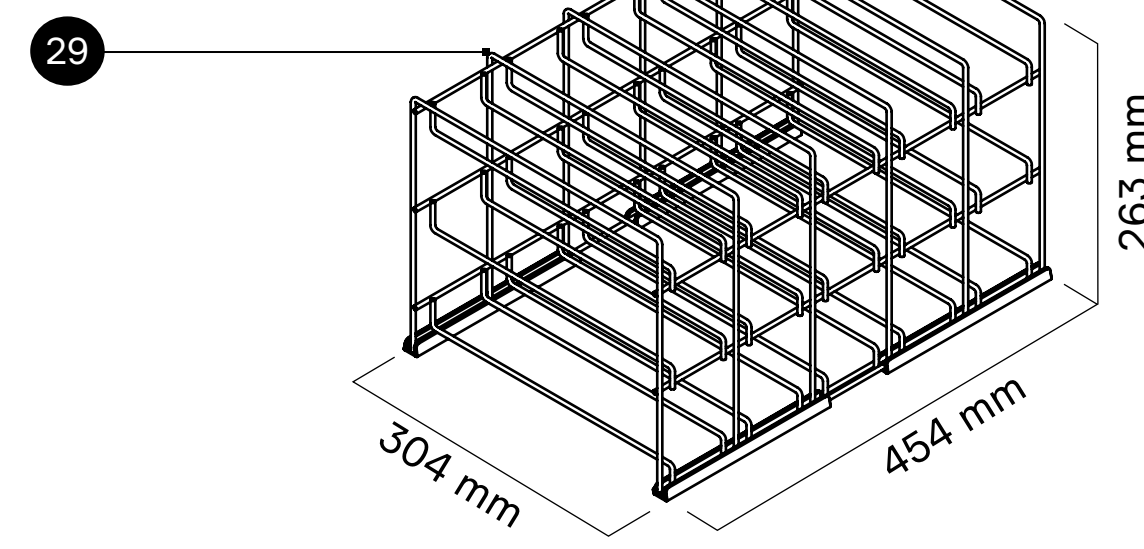

Narrow box zigzag
expositor 8 bottles

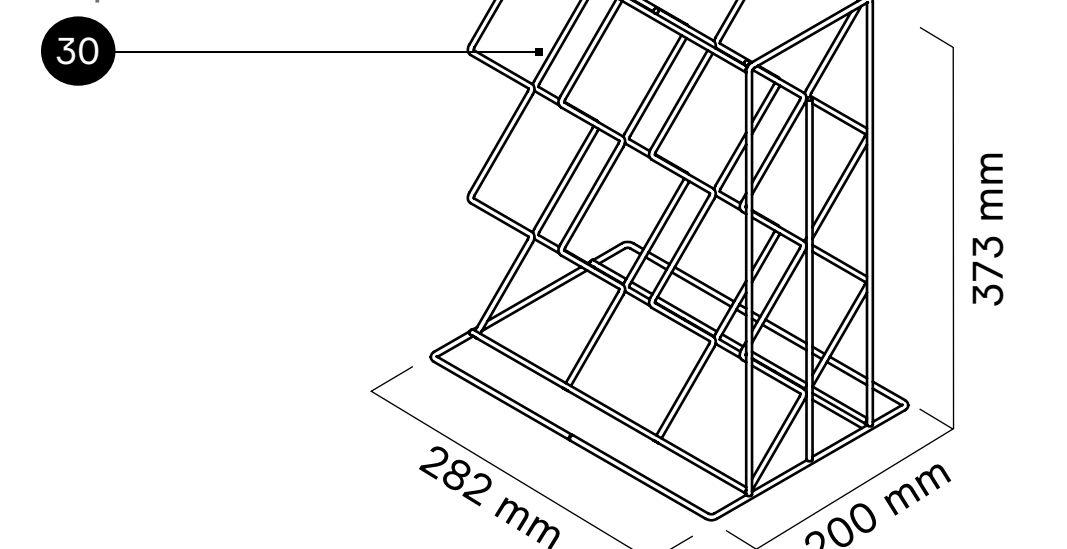

Archiw's well-designed details



Vertical perforation of frame allows to place shelves with step of 10 cm



Strong magnets safely fix expositors on the shelf



Rubber inserts for fixing bottles



Swivel wheels for great maneuverability

Mobile





Stationary

Adjustable legs inserts provide stability even on uneven surfaces

Easily assemble elements into Archiw modules

Article	Elements	Facade stationary	Facade mobile	Block	Platform
Basic elements					
1 1018-712-10	Basic section Facade Stationary Wide	1			
2 1018-713-10	Basic section Facade Stationary Narrow		1		
3 1018-743-10	Extension section Facade stationary Wide	max 10			
4 1018-744-10	Extension section Facade stationary Narrow	max 10			
5 1018-710-10	Basic section Facade Mobile Wide		1		
6 1018-711-10	Basic section Facade Mobile Narrow			1	
7 1018-741-10	Extension section Facade Mobile Wide		max 10		
8 1018-742-10	Extension section Facade Mobile Narrow		max 10		
9 1018-723-10	Sidewall Fasade	1	1		
10 1018-579-F9	Basic section Block			1	
11 1018-591-F9	Extension section Block			1–5	
12 1018-553-F9	Sidewall Block			1	
13 1017-102-F9	Framework Platform				•
Support elements					
14 4037-007-04	Insert adjustable	4 / section			
15 4001-292-46	Wheel with stopper		4 basic + 2 / each 2 sections	4 basic + 2 / each 2 sections	2
Shelves and accessories					
17 1019-466-10	Metal narrow shelf	max 10 / section	max 10 / section		
18 1019-467-10	Metal wide shelf	max 10 / section	max 10 / section		
19 1017-914-10	Bracket	2 /shelf	2 /shelf		
20 1017-040-F9	Plywood box narrow	max 2 / cection	max 2 / cection		
21 1017-036-F9	Plywood box wide	max 2 / cection	max 2 / cection		
22 1019-420-00	Plywood shelf			3 / section	
23 1017-046-F9	Wide box expositor inclined low	max 2	max 2		
24 1017-047-F9	Wide box expositor inclined high	max 2	max 2		
25 1017-044-F9	Wide Shelf expositor inclined low	1 / shelf	1 / shelf	2 / shelf	max 4
26 1017-045-F9	Wide Shelf expositor inclined high	1 / shelf	1 / shelf	2 / shelf	max 4
27 1017-109-F9	Wire expositor narrow	1/ shelf (box)	1/ shelf (box)	2 / shelf	
28 1017-110-F9	Wire expositor wide	1/ shelf (box)	1/ shelf (box)	2 / shelf	
29 1017-111-F9	Wide shelf wire expositor low	1/ shelf	1/ shelf	2 / shelf	max 4
30 1018-499-F9	Narrow box zigzag expositor	max 2	max 2		

 main elements

 optional elements

Archiw's RAL Identity



RURAL
RAL 9005



URBAN
RAL 7016

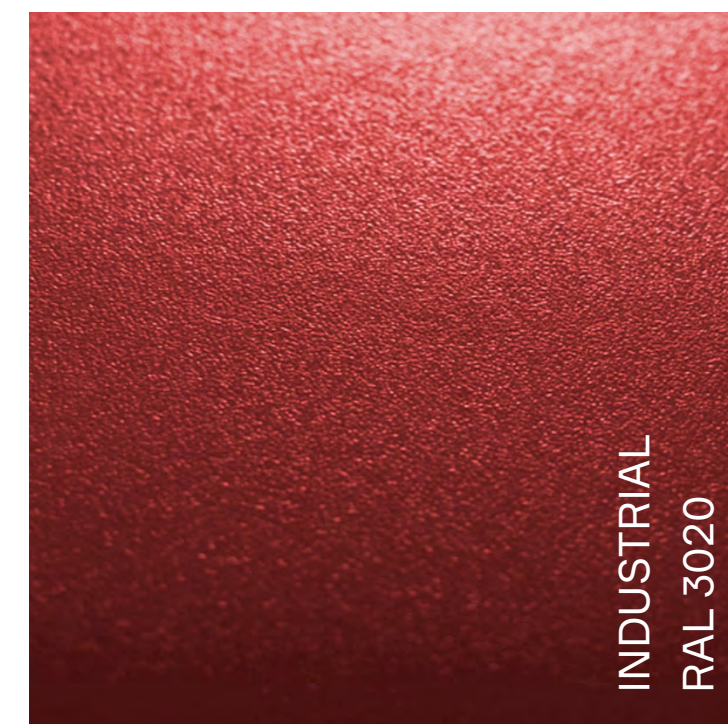

INDUSTRIAL
RAL 3020



MODERN EXPO

Head Office
Modern Expo Lutsk, Ukraine

T +380 (332) 78 95 00

info@modern-expo.com

modern-expo.eu

Office in Poland
Lublin
T +48 (81) 744 50 50
biurohandlowe@modern-expo.pl

Office in Germany
Berlin
T +49 (0) 171 222 12 93
officeberlin@modern-expo.de

Office in France
Wissous
T +33 (7) 67 03 03 35
contact@modern-expo.com

Office in UK
London
T +44 (0) 7534 635 103
uk.sales@modern-expo.com

Office in the Middle East
Dubai, UAE
T +971 (0) 4 557 8311
uae@modern-expo.com